

MECHANICAL FORKLIFT MHS-1.5-1254

The forklift is a compact product for light and delicate loads up to 150 kg. It is extremely maneuverable, suitable for indoor use in tight spaces and warehouses, and easily passes through standard doors. It is designed for transporting and lifting loads as part of an internal production line. The loading platform is lifted and lowered by manual rope winch. The castors are rotating, with non-marking rubber wheels with diameter 100 mm. Two of the castors have brakes for stable fixing of the equipment when needed.

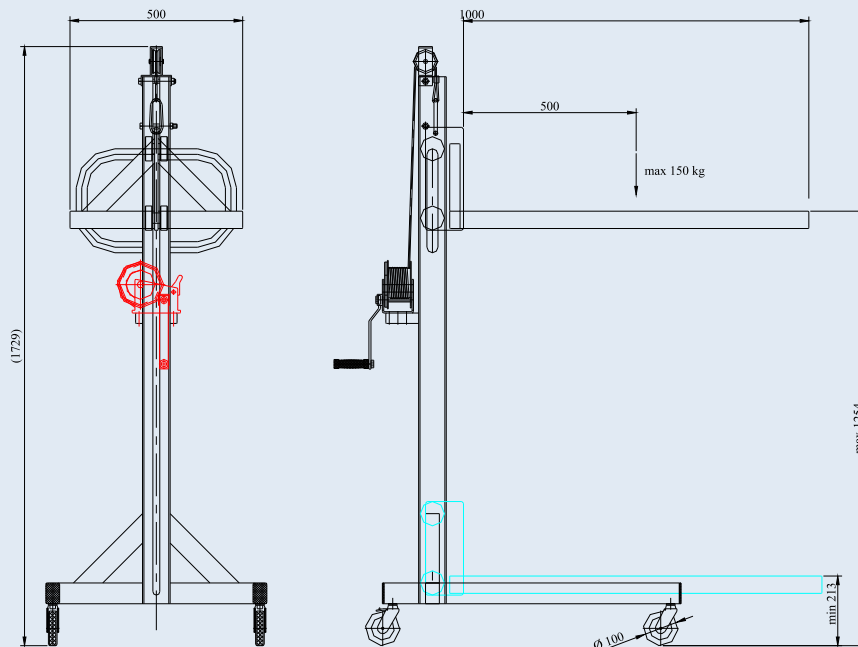

MECHANICAL FORKLIFT

Товароносимост, kg
 Дължина на товарната платформа, mm
 Външна широчина на товарната платформа, mm
 Височина на повдигане, mm
 Диаметър на колелата, mm
 Подемен механизъм, type
 Габаритни размери, mm
 - дължина
 - широчина
 - височина
 Собствена маса, kg

MHS-1.5-1254

150
 500
 1032
 1254
 100
 механичен
 1273
 640
 1729
 54.8