

Wheels and castors with polyurethane tread

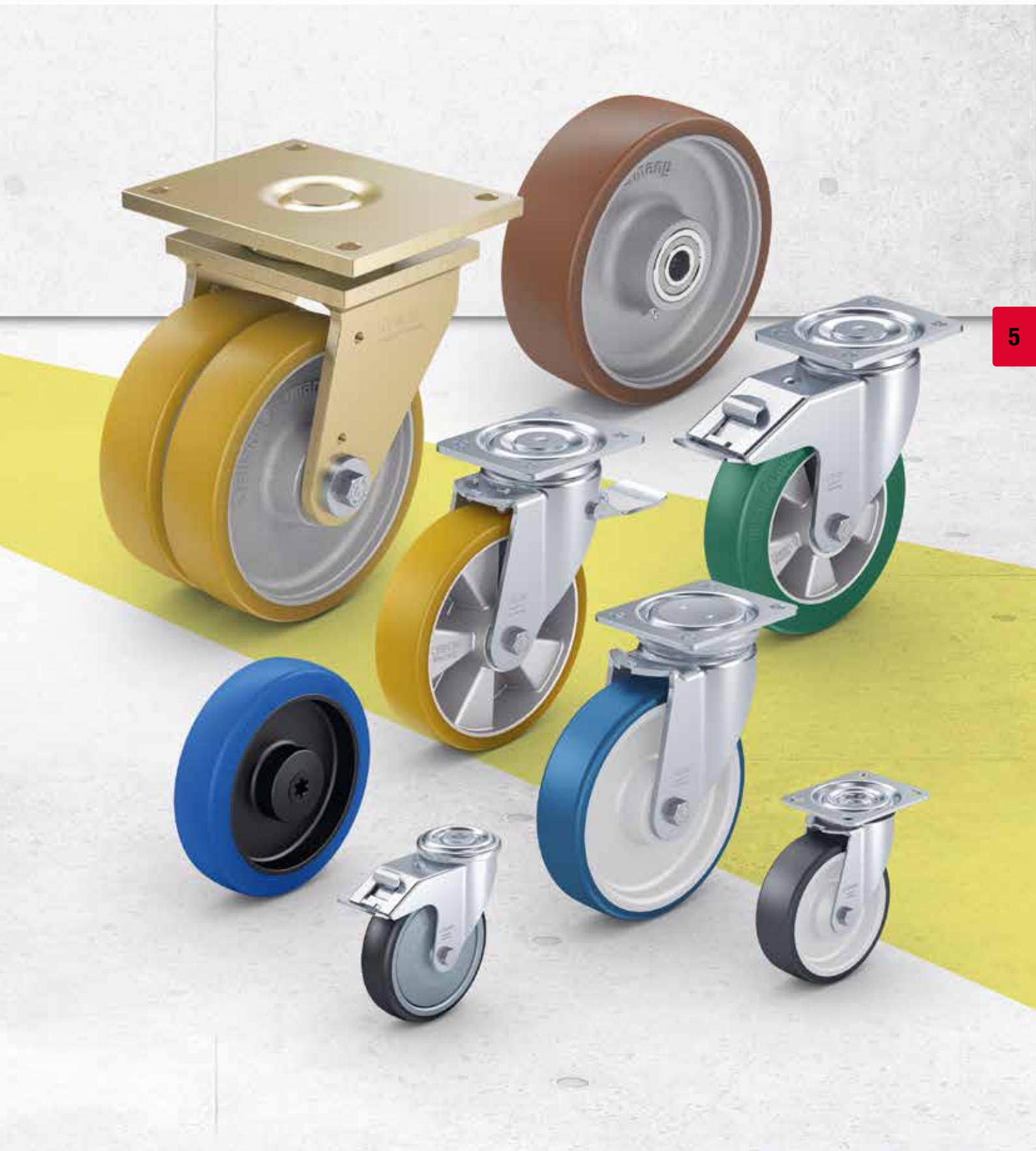

5

Selection tool

Wheels and castors with polyurethane tread



Series	PATH	POTH	POTHS	ALTH	SETH	VSTH / GTH
Category	Standard polyurethane					
Tread / tyre	Thermoplastic polyurethane (TPU)			Polyurethane elastomer Blickle Extrathane®		
Tread and tyre hardness	94 Shore A	94 Shore A	80 Shore A	92 Shore A	92 Shore A	92 Shore A
Electrical conductivity	optional	–	–	optional	–	optional
Wheel centre / rim	nylon	nylon	nylon	aluminium	thick-walled pressed steel	VSTH: steel GTH: grey cast iron
Wheel Ø	80–200 mm	75–250 mm	100–200 mm	80–250 mm	125–250 mm	35–1,000 mm
Load capacity up to	500 kg	1,000 kg	550 kg	1,250 kg	1,350 kg	30,000 kg
Rolling resistance	■ ■ ■ ■ ■	■ ■ ■ ■ ■	■ ■ ■ ■ ■	■ ■ ■ ■ ■	■ ■ ■ ■ ■	■ ■ ■ ■ ■
Smooth operation and floor preservation	■ ■ ■ ■ ■	■ ■ ■ ■ ■	■ ■ ■ ■ ■	■ ■ ■ ■ ■	■ ■ ■ ■ ■	■ ■ ■ ■ ■
Speeds up to	4 km/h	4 km/h	4 km/h	10 km/h	10 km/h	10 km/h
Use in wet areas	(✓)	(✓)	✓	–	–	–
For a description of the wheel, refer to	page 258	page 263	page 270	page 274	page 282	page 286–287
For information about swivel and fixed castors, refer to	page 259–262	page 264–269	page 271–273	page 275–281	page 283–285	page 288–293

■ ■ ■ ■ ■ excellent
 ■ ■ ■ ■ ■ very good
 ■ ■ ■ ■ ■ good
 ■ ■ ■ ■ ■ satisfactory
 ■ ■ ■ ■ ■ adequate
 ✓ yes – no

ALTH series

Heavy-duty wheels with Blickle Extrathane® polyurethane tread, with aluminium wheel centre

200–1,250 kg

Tread and tyre hardness

92 Shore A

Smooth operation / floor preservation

good

Rolling resistance

very good

Wear resistance

excellent



Tread:

- high-quality polyurethane elastomer Blickle Extrathane®, hardness 92 Shore A
- low rolling resistance
- high abrasion resistance
- high cut and tear propagation resistance
- colour light brown, non-marking, non-staining
- excellent chemical connection with the wheel centre

Wheel centre:

- die-cast aluminium

Other features:

- high chemical resistance to many aggressive substances
- operating temperature: -20 °C to +70 °C, temporarily up to +90 °C, reduced load capacity over +40 °C

Additional details:

- wheel series: page 65
- tread: page 55
- bearing types: page 84–85
- chemical resistance: page 51

Wheels	Wheel Ø (D) [mm]	Wheel width (T2) [mm]	Load capacity at 4 km/h [kg]	Load capacity at 10 km/h [kg]	Bearing type	Axle bore Ø (d) [mm]	Hub length (T1) [mm]
ALTH 80/15K	80	30	200	–	ball bearing	15	35
ALTH 100/15K	100	40	350	–	ball bearing	15	45
ALTH 101/15K *	100	40	420	–	ball bearing	15	40
ALTH 101/15K-CO *	100	40	420	–	ball bearing	15	40
ALTH 125/15K	125	40	550	–	ball bearing	15	45
ALTH 125/15K-CO	125	40	550	–	ball bearing	15	45
ALTH 127/20K	125	54	750	370	ball bearing	20	60
ALTH 140/20K	140	54	800	400	ball bearing	20	60
ALTH 151/15K	150	40	400	200	ball bearing	15	60
ALTH 150/20K	150	50	650	320	ball bearing	20	60
ALTH 152/20K *	150	54	900	450	ball bearing	20	60
ALTH 160/20K	160	50	750	370	ball bearing	20	60
ALTH 160/20K-CO	160	50	750	300	ball bearing	20	60
ALTH 162/20K *	160	50	950	470	ball bearing	20	60
ALTH 180/20K	180	50	700	350	ball bearing	20	60
ALTH 200/20K	200	50	800	400	ball bearing	20	60
ALTH 200/20K-CO	200	50	800	320	ball bearing	20	60
ALTH 200/25K	200	50	800	400	ball bearing	25	60
ALTH 200/25K-CO	200	50	800	320	ball bearing	25	60
ALTH 202/20K *	200	50	1,000	500	ball bearing	20	60
ALTH 250/25K	250	60	1,000	500	ball bearing	25	70
ALTH 252/25K *	250	60	1,250	620	ball bearing	25	70

* With heavy-duty wheel centre, reinforced design

Versions / options



	version with extremely crowned tread	version with heavy duty wheel centre, reinforced design	antistatic version, non-marking grey	other shore hardnesses and special colours
Technical description page	55		50	
Product code suffix	-CO		-AS	
Available for			all with exception of wheel Ø 140 mm	upon request

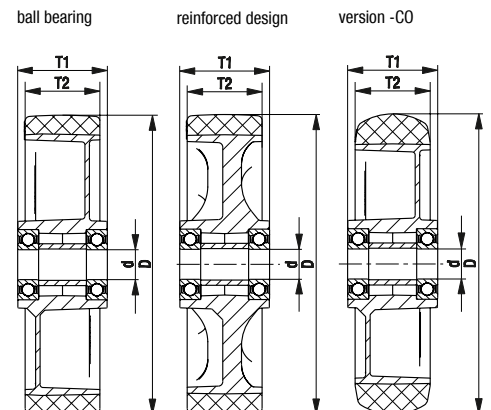

L-ALTH, B-ALTH, BH-ALTH series

Pressed steel castors, medium-duty version, with top plate, wheel with Blickle Extrathane® polyurethane tread

200–500 kg

Bracket: L/B/BH series

- pressed steel, zinc-plated, blue-passivated, Cr6-free

Swivel bracket:

- double ball bearing in the swivel head
- strong central kingpin (from wheel Ø 150 mm)
- swivel head seal
- minimum swivel head play and smooth rolling characteristic and increased service life due to the special dynamic Blickle riveting process

Wheel: ALTH series

- tread: high-quality polyurethane elastomer Blickle Extrathane®, hardness 92 Shore A, colour light brown, non-marking, non-staining
- wheel centre: die-cast aluminium, colour silver grey

Additional details:

- bracket series: page 91
- brakes: page 112–113
- wheel series: page 274
- bearing types: page 84–85

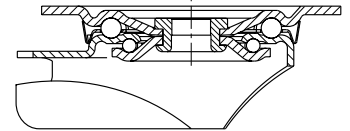

5

Swivel castors	Fixed castors	Swivel castors with "stop-fix" brake	Wheel Ø [mm]	Wheel width [mm]	Load capacity [kg]	Bearing type	Total height [mm]	Plate size [mm]	Bolt hole spacing [mm]	Bolt hole Ø [mm]	Offset swivel castor [mm]
L-ALTH 80K	B-ALTH 80K	L-ALTH 80K-FI	80	30	200	ball bearing	102	100 x 85	80 x 60	9	38
L-ALTH 100K	B-ALTH 100K	L-ALTH 100K-FI	100	40	250	ball bearing	125	100 x 85	80 x 60	9	36
L-ALTH 125K	B-ALTH 125K	L-ALTH 125K-FI	125	40	250	ball bearing	150	100 x 85	80 x 60	9	38
L-ALTH 125K-CO	B-ALTH 125K-CO	L-ALTH 125K-FI-CO	125	40	250	ball bearing	150	100 x 85	80 x 60	9	38
L-ALTH 151K	B-ALTH 151K	L-ALTH 151K-FI	150	40	400	ball bearing	190	140 x 110	105 x 75–80	11	60
L-ALTH 150K	B-ALTH 150K	L-ALTH 150K-FI	150	50	400	ball bearing	190	140 x 110	105 x 75–80	11	60
L-ALTH 160K	B-ALTH 160K	L-ALTH 160K-FI	160	50	400	ball bearing	195	140 x 110	105 x 75–80	11	60
L-ALTH 160K-CO	B-ALTH 160K-CO	L-ALTH 160K-FI-CO	160	50	400	ball bearing	195	140 x 110	105 x 75–80	11	60
L-ALTH 180K	B-ALTH 180K	L-ALTH 180K-FI	180	50	400	ball bearing	215	140 x 110	105 x 75–80	11	60
L-ALTH 200K	B-ALTH 200K	L-ALTH 200K-FI	200	50	400	ball bearing	235	140 x 110	105 x 75–80	11	65
L-ALTH 200K-CO	B-ALTH 200K-CO	L-ALTH 200K-FI-CO	200	50	400	ball bearing	235	140 x 110	105 x 75–80	11	65
L-ALTH 250K-3	BH-ALTH 250K	*	250	60	500	ball bearing	295	140 x 110	105 x 75–80	11	77

* "stop-top" brake version, see versions / options

Versions / options



	version with extremely crowned tread	antistatic version, non-marking grey	with "stop-top" brake	with "central-stop" central brake system	directional lock (separate) 1 x 360°	directional lock (separate) 1 x 360°	with steel foot guard
Technical description page	55	50	112	113	115	115	116
Product code suffix	-CO	-AS	-ST	-CS11	RI-03.01	RI-05.03	-FS
Available for		all	all	wheel Ø 160+200 mm	wheel Ø 100–125 mm**	wheel Ø 150–200 mm**	wheel Ø 100–250 mm

** Only for swivel castors without brake or swivel castor with "stop-top" and "central-stop" brake upon request

LK-ALTH, BK-ALTH, BH-ALTH series

Pressed steel castors, heavy-duty design, with top plate, wheel with Blickle Extrathane® polyurethane tread

200–600 kg

Bracket: LK/BK/BH series

- strong pressed steel, zinc-plated, blue-passivated, Cr6-free

Swivel bracket:

- double ball bearing in the swivel head
- strong central kingpin (from wheel Ø 125x50 mm)
- swivel head seal
- minimum swivel head play and smooth rolling characteristic and increased service life due to the special dynamic Blickle riveting process

Wheel: ALTH series

- tread: high-quality polyurethane elastomer Blickle Extrathane®, hardness 92 Shore A, colour light brown, non-marking, non-staining
- wheel centre: die-cast aluminium, colour silver grey

Additional details:

- bracket series: page 92
- brakes: page 112–113
- wheel series: page 274
- bearing types: page 84–85



5

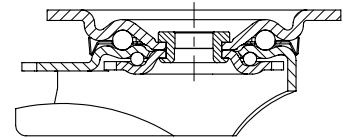

Swivel castors	Fixed castors	Swivel castors with "stop-fix" brake	Wheel Ø [mm]	Wheel width [mm]	Load capacity [kg]	Bearing type	Total height [mm]	Plate size [mm]	Bolt hole spacing [mm]	Bolt hole Ø [mm]	Offset swivel castor [mm]
LK-ALTH 80K	BK-ALTH 80K	LK-ALTH 80K-FI	80	30	200	ball bearing	110	100 x 85	80 x 60	9	40
LK-ALTH 100K-1	BK-ALTH 100K-1	LK-ALTH 100K-1-FI	100	40	350	ball bearing	130	100 x 85	80 x 60	9	45
LK-ALTH 100K-3	BK-ALTH 100K-3	LK-ALTH 100K-3-FI	100	40	350	ball bearing	130	140 x 110	105 x 75–80	11	45
LK-ALTH 125K-1	BK-ALTH 125K-1	LK-ALTH 125K-1-FI	125	40	350	ball bearing	155	100 x 85	80 x 60	9	48
LK-ALTH 125K-1-CO	BK-ALTH 125K-1-CO	LK-ALTH 125K-1-FI-CO	125	40	350	ball bearing	155	100 x 85	80 x 60	9	48
LK-ALTH 125K-3	BK-ALTH 125K-3	LK-ALTH 125K-3-FI	125	40	350	ball bearing	155	140 x 110	105 x 75–80	11	48
LK-ALTH 125K-3-CO	BK-ALTH 125K-3-CO	LK-ALTH 125K-3-FI-CO	125	40	350	ball bearing	155	140 x 110	105 x 75–80	11	48
LK-ALTH 127K	BH-ALTH 127K	LK-ALTH 127K-FI	125	54	600	ball bearing	170	140 x 110	105 x 75–80	11	55
LK-ALTH 150K	BH-ALTH 150K	LK-ALTH 150K-FI	150	50	600	ball bearing	197	140 x 110	105 x 75–80	11	60
LK-ALTH 160K	BH-ALTH 160K	LK-ALTH 160K-FI	160	50	600	ball bearing	202	140 x 110	105 x 75–80	11	60
LK-ALTH 160K-CO	BH-ALTH 160K-CO	LK-ALTH 160K-FI-CO	160	50	600	ball bearing	202	140 x 110	105 x 75–80	11	60
LK-ALTH 180K	BH-ALTH 180K	LK-ALTH 180K-FI	180	50	600	ball bearing	223	140 x 110	105 x 75–80	11	65
LK-ALTH 200K	BH-ALTH 200K	LK-ALTH 200K-FI	200	50	600	ball bearing	245	140 x 110	105 x 75–80	11	62
LK-ALTH 200K-CO	BH-ALTH 200K-CO	LK-ALTH 200K-FI-CO	200	50	600	ball bearing	245	140 x 110	105 x 75–80	11	62

Versions / options



	version with extremely crowned tread	antistatic version, non-marking grey	with "stop-top" brake	with "ideal-stop" brake total height +17 mm	with directional lock (separate) 1x 360°	with steel foot guard
Technical description page	55	50	112	112	115	116
Product code suffix	-CO	-AS	-ST	-IS	see **	-FS
Available for		all	all	wheel Ø 160+200 mm*	for wheel Ø and plate dimensions, see**	upon request

* Synthetic adapter plate to balance out total height for swivel and fixed castors without "ideal-stop" brake: **product code AP3-17**

** **RI-05.01** for wheel Ø 80–125 mm with plate 100x85 mm, **RI-03.03** for wheel Ø 100–125x40 mm with plate 140x110 mm, **RI-05.03** for wheel Ø 125x54–200 mm (Only for swivel castors without brake or swivel castor with "stop-top" brake upon request)

LKR-ALTH series

Pressed steel castors, heavy-duty design, with bolt hole, wheel with Blickle Extrathane® polyurethane tread



200–350 kg

Bracket: LKR series

- strong pressed steel, zinc-plated, blue-passivated, Cr6-free
- double ball bearing in the swivel head
- strong central kingpin
- minimum swivel head play and smooth rolling characteristic and increased service life due to the special dynamic Blickle riveting process

Wheel: ALTH series

- tread: high-quality polyurethane elastomer Blickle Extrathane®, hardness 92 Shore A, colour light brown, non-marking, non-staining
- wheel centre: die-cast aluminium, colour silver grey

Additional details:

- bracket series: page 92
- brakes: page 112–113
- wheel series: page 274
- bearing types: page 84–85

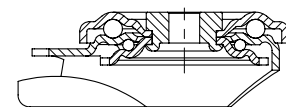

5

Swivel castors	Swivel castors with "stop-fix" brake	Wheel Ø [mm]	Wheel width [mm]	Load capacity [kg]	Bearing type	Total height [mm]	Plate Ø [mm]	Bolt hole Ø [mm]	Offset swivel castor [mm]
LKR-ALTH 80K	LKR-ALTH 80K-FI	80	30	200	ball bearing	110	88	13	40
LKR-ALTH 100K	LKR-ALTH 100K-FI	100	40	350	ball bearing	130	88	13	45
LKR-ALTH 125K	LKR-ALTH 125K-FI	125	40	350	ball bearing	155	88	13	48
LKR-ALTH 125K-CO	LKR-ALTH 125K-FI-CO	125	40	350	ball bearing	155	88	13	48

Versions / options



	version with extremely crowned tread	antistatic version, non-marking grey	truck lock
Technical description page	55	50	114
Product code suffix	-CO	-AS	FF 100-1 / FF 125-1
Available for		all	wheel Ø 100+125 mm

LH-ALTH, BH-ALTH series

Pressed steel castors, heavy-duty design, with top plate, wheel with Blickle Extrathane® polyurethane tread

200–900 kg



Bracket: LH/BH series

- strong pressed steel, zinc-plated, blue-passivated, Cr6-free

- heavy fork and top plate

Swivel bracket:

- double ball bearing in the swivel head
- bolted and secured central kingpin, extremely strong
- particularly resistant to shocks and impact due to **four specially-shaped, hardened bearing seats**

Wheel: ALTH series

- tread: high-quality polyurethane elastomer Blickle Extrathane®, hardness 92 Shore A, colour light brown, non-marking, non-staining
- wheel centre: die-cast aluminium, colour silver grey

Additional details:

- bracket series: page 92
- brakes: page 112–113
- wheel series: page 274
- bearing types: page 84–85



5

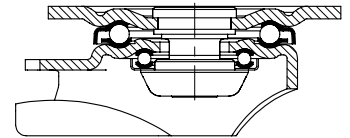

Swivel castors	Fixed castors	Swivel castors with "stop-fix" brake	Wheel Ø [mm]	Wheel width [mm]	Load capacity [kg]	Bearing type	Total height [mm]	Plate size [mm]	Bolt hole spacing [mm]	Bolt hole Ø [mm]	Offset swivel castor [mm]
LH-ALTH 80K	BH-ALTH 80K	LH-ALTH 80K-FI	80	30	200	ball bearing	120	100 x 85	80 x 60	9	45
LH-ALTH 100K-1	BH-ALTH 100K-1	LH-ALTH 100K-1-FI	100	40	350	ball bearing	140	100 x 85	80 x 60	9	45
LH-ALTH 101K-1 *	BH-ALTH 101K-1 *	LH-ALTH 101K-1-FI *	100	40	420	ball bearing	140	100 x 85	80 x 60	9	45
LH-ALTH 101K-1-CO *	BH-ALTH 101K-1-CO *	LH-ALTH 101K-1-FI-CO *	100	40	420	ball bearing	140	100 x 85	80 x 60	9	45
LH-ALTH 100K-3	BH-ALTH 100K-3	LH-ALTH 100K-3-FI	100	40	350	ball bearing	140	140 x 110	105 x 75–80	11	45
LH-ALTH 101K-3 *	BH-ALTH 101K-3 *	LH-ALTH 101K-3-FI *	100	40	420	ball bearing	140	140 x 110	105 x 75–80	11	45
LH-ALTH 101K-3-CO *	BH-ALTH 101K-3-CO *	LH-ALTH 101K-3-FI-CO *	100	40	420	ball bearing	140	140 x 110	105 x 75–80	11	45
LH-ALTH 125K-1	BH-ALTH 125K-1	LH-ALTH 125K-1-FI	125	40	550	ball bearing	165	100 x 85	80 x 60	9	45
LH-ALTH 125K-1-CO	BH-ALTH 125K-1-CO	LH-ALTH 125K-1-FI-CO	125	40	550	ball bearing	165	100 x 85	80 x 60	9	45
LH-ALTH 125K-3	BH-ALTH 125K-3	LH-ALTH 125K-3-FI	125	40	550	ball bearing	165	140 x 110	105 x 75–80	11	45
LH-ALTH 125K-3-CO	BH-ALTH 125K-3-CO	LH-ALTH 125K-3-FI-CO	125	40	550	ball bearing	165	140 x 110	105 x 75–80	11	45
LH-ALTH 127K	BH-ALTH 127K	LH-ALTH 127K-FI	125	54	750	ball bearing	170	140 x 110	105 x 75–80	11	55
LH-ALTH 150K	BH-ALTH 150K	LH-ALTH 150K-FI	150	50	650	ball bearing	197	140 x 110	105 x 75–80	11	65
LH-ALTH 152K *	BH-ALTH 152K *	LH-ALTH 152K-FI *	150	54	900	ball bearing	197	140 x 110	105 x 75–80	11	65
LH-ALTH 160K	BH-ALTH 160K	LH-ALTH 160K-FI	160	50	750	ball bearing	202	140 x 110	105 x 75–80	11	65
LH-ALTH 160K-CO	BH-ALTH 160K-CO	LH-ALTH 160K-FI-CO	160	50	750	ball bearing	202	140 x 110	105 x 75–80	11	65
LH-ALTH 162K *	BH-ALTH 162K *	LH-ALTH 162K-FI *	160	50	900	ball bearing	202	140 x 110	105 x 75–80	11	65
LH-ALTH 180K	BH-ALTH 180K	LH-ALTH 180K-FI	180	50	700	ball bearing	223	140 x 110	105 x 75–80	11	67
LH-ALTH 200K	BH-ALTH 200K	LH-ALTH 200K-FI	200	50	800	ball bearing	245	140 x 110	105 x 75–80	11	70
LH-ALTH 200K-CO	BH-ALTH 200K-CO	LH-ALTH 200K-FI-CO	200	50	800	ball bearing	245	140 x 110	105 x 75–80	11	70
LH-ALTH 202K *	BH-ALTH 202K *	LH-ALTH 202K-FI *	200	50	900	ball bearing	245	140 x 110	105 x 75–80	11	70
LH-ALTH 250K	BH-ALTH 250K	**	250	60	900	ball bearing	295	140 x 110	105 x 75–80	11	82
LH-ALTH 252K *	BH-ALTH 252K *	**	250	60	900	ball bearing	295	140 x 110	105 x 75–80	11	82

* Heavy-duty wheel version

** "stop-top" brake version, see versions / options

Versions / options***



	version with extremely crowned tread	version with heavy duty wheel centre, reinforced design	antistatic version, non-marking grey	with "stop-top" brake	with "central-stop" central brake system	with "ideal-stop" brake total height +17 mm	with directional lock (separate) 1x 360°
Technical description page	55		50	112	113	112	115
Product code suffix	-CO		-AS	-ST	-CS13	-IS	see ****
Available for			all	all	wheel Ø 160+200 mm	wheel Ø 160+200 mm****	for wheel Ø and plate dimensions, see****

*** **Additional versions / options:** with steel foot guard (-FS), available for wheel Ø 100–250 mm

**** Synthetic adapter plate to balance out total height for swivel and fixed castors without "ideal-stop" brake: **product code AP3-17**

***** **RI-04.01** for wheel Ø 80–125 mm with plate 100x85 mm, **RI-04.03** for wheel Ø 100–125x40 mm with plate 140x110 mm, **RI-05.03** for wheel Ø 125x54–200 mm (Only for swivel castors without brake or swivel castor with "stop-top" and "central-stop" brake upon request)

LHZ-ALTH series

Pressed steel castors, heavy-duty design, with stem, wheel with Blickle Extrathane® polyurethane tread



750–900 kg

Bracket: LHZ series

- strong pressed steel, zinc-plated, blue-passivated, Cr6-free
- heavy fork and top plate
- double ball bearing in the swivel head
- very strong, welded steel plug-in stem, bolted and secured
- particularly resistant to shocks and impact due to **four specially-shaped, hardened bearing seats**

Wheel: ALTH series

- tread: high-quality polyurethane elastomer Blickle Extrathane®, hardness 92 Shore A, colour light brown, non-marking, non-staining
- wheel centre: die-cast aluminium, colour silver grey

Additional details:

- bracket series: page 92
- brakes: page 112–113
- wheel series: page 274
- bearing types: page 84–85

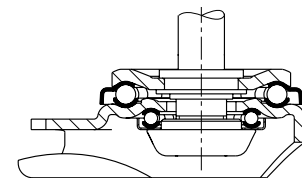

5

Swivel castors	Swivel castors with "stop-fix" brake	Wheel Ø [mm]	Wheel width [mm]	Load capacity [kg]	Bearing type	Total height [mm]	Stem Ø [mm]	Stem length [mm]	Offset swivel castor [mm]
LHZ-ALTH 127K	LHZ-ALTH 127K-FI	125	54	750	ball bearing	170	27	60	55
LHZ-ALTH 160K	LHZ-ALTH 160K-FI	160	50	750	ball bearing	202	27	60	65
LHZ-ALTH 160K-CO	LHZ-ALTH 160K-FI-CO	160	50	750	ball bearing	202	27	60	65
LHZ-ALTH 162K *	LHZ-ALTH 162K-FI *	160	50	900	ball bearing	202	27	60	65
LHZ-ALTH 200K	LHZ-ALTH 200K-FI	200	50	800	ball bearing	245	27	60	70
LHZ-ALTH 200K-CO	LHZ-ALTH 200K-FI-CO	200	50	800	ball bearing	245	27	60	70
LHZ-ALTH 202K *	LHZ-ALTH 202K-FI *	200	50	900	ball bearing	245	27	60	70

* Heavy-duty wheel version

Versions / options



	version with extremely crowned tread	version with heavy duty wheel centre, reinforced design	antistatic version, non-marking grey	with "stop-top" brake	with steel foot guard
Technical description page	55		50	112	116
Product code suffix	-CO		-AS	-ST	-FS
Available for			all	all	upon request

LUH-ALTH, BH-ALTH series

Pressed steel castors, heavy-duty design, enclosed, with top plate, wheel with Blickle Extrathane® polyurethane tread



650–1,000 kg

Bracket: LUH/BH series

- strong pressed steel, zinc-plated, blue-passivated, Cr6-free

Swivel bracket:

- four-point ball bearing for extremely heavy loads
- enclosed and sealed swivel head
- particularly resistant to shocks and impact due to **specialty-shaped, hardened bearing seats**

Wheel: ALTH series

- tread: high-quality polyurethane elastomer Blickle Extrathane®, hardness 92 Shore A, colour light brown, non-marking, non-staining
- wheel centre: die-cast aluminium, colour silver grey

Additional details:

- bracket series: page 93
- brakes: page 112–113
- wheel series: page 274
- bearing types: page 84–85



5

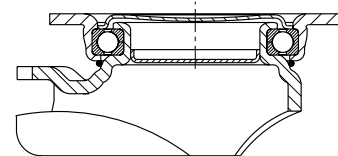

Swivel castors	Fixed castors	Swivel castors with "stop-fix" brake	Wheel Ø [mm]	Wheel width [mm]	Load capacity [kg]	Bearing type	Total height [mm]	Plate size [mm]	Bolt hole spacing [mm]	Bolt hole Ø [mm]	Offset swivel castor [mm]
LUH-ALTH 127K	BH-ALTH 127K	LUH-ALTH 127K-FI	125	54	750	ball bearing	170	140 x 110	105 x 75–80	11	55
LUH-ALTH 150K	BH-ALTH 150K	LUH-ALTH 150K-FI	150	50	650	ball bearing	197	140 x 110	105 x 75–80	11	61
LUH-ALTH 152K *	BH-ALTH 152K *	LUH-ALTH 152K-FI *	150	54	900	ball bearing	197	140 x 110	105 x 75–80	11	61
LUH-ALTH 160K	BH-ALTH 160K	LUH-ALTH 160K-FI	160	50	750	ball bearing	202	140 x 110	105 x 75–80	11	61
LUH-ALTH 160K-CO	BH-ALTH 160K-CO	LUH-ALTH 160K-FI-CO	160	50	750	ball bearing	202	140 x 110	105 x 75–80	11	61
LUH-ALTH 162K *	BH-ALTH 162K *	LUH-ALTH 162K-FI *	160	50	950	ball bearing	202	140 x 110	105 x 75–80	11	61
LUH-ALTH 200K	BH-ALTH 200K	LUH-ALTH 200K-FI	200	50	800	ball bearing	245	140 x 110	105 x 75–80	11	63
LUH-ALTH 200K-CO	BH-ALTH 200K-CO	LUH-ALTH 200K-FI-CO	200	50	800	ball bearing	245	140 x 110	105 x 75–80	11	63
LUH-ALTH 202K *	BH-ALTH 202K *	LUH-ALTH 202K-FI *	200	50	1,000	ball bearing	245	140 x 110	105 x 75–80	11	63

* Heavy-duty wheel version

Versions / options



	version with extremely crowned tread	version with heavy duty wheel centre, reinforced design	antistatic version, non-marking grey	directional lock (separate) 1 x 360°	with steel foot guard
Technical description page	55		50	115	116
Product code suffix	-CO		-AS	RI-05.03	-FS
Available for			all	all**	upon request

** Only for swivel castors without brake

LO-ALTH, BO-ALTH series

**Welded steel heavy-duty castors,
wheel with polyurethane tread
Blickle Extrathane®**

650–1,200 kg

Bracket: LO/BO series

- solid welded steel construction, zinc-plated, blue-passivated, Cr6-free

Swivel bracket:

- double ball bearing in the swivel head
- **four specially-shaped, hardened bearing seats** for additional strength
- bolted and secured welded central kingpin, extremely strong
- swivel head seal with labyrinth design
- grease nipple

Wheel: ALTH series

- tread: high-quality polyurethane elastomer Blickle Extrathane®, hardness 92 Shore A, colour light brown, non-marking, non-staining
- wheel centre: die-cast aluminium, colour silver grey

Additional details:

- bracket series: page 93
- brakes: page 112–113
- wheel series: page 274
- bearing types: page 84–85

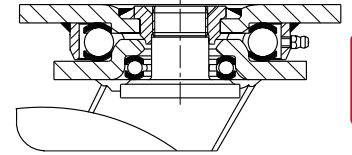

5

Swivel castors	Fixed castors	Swivel castor with "stop-top" brake	Wheel Ø [mm]	Wheel width [mm]	Load capacity [kg]	Bearing type	Total height [mm]	Plate size [mm]	Bolt hole spacing [mm]	Bolt hole Ø [mm]	Offset swivel castor [mm]
LO-ALTH 127K	BO-ALTH 127K	LO-ALTH 127K-ST	125	54	750	ball bearing	170	140 x 110	105 x 75–80	11	50
LO-ALTH 150K	BO-ALTH 150K	LO-ALTH 150K-ST	150	50	650	ball bearing	200	140 x 110	105 x 75–80	11	55
LO-ALTH 152K *	BO-ALTH 152K *	LO-ALTH 152K-ST *	150	54	900	ball bearing	200	140 x 110	105 x 75–80	11	55
LO-ALTH 160K	BO-ALTH 160K	LO-ALTH 160K-ST	160	50	750	ball bearing	205	140 x 110	105 x 75–80	11	55
LO-ALTH 160K-CO	BO-ALTH 160K-CO	LO-ALTH 160K-ST-CO	160	50	750	ball bearing	205	140 x 110	105 x 75–80	11	55
LO-ALTH 162K *	BO-ALTH 162K *	LO-ALTH 162K-ST *	160	50	950	ball bearing	205	140 x 110	105 x 75–80	11	55
LO-ALTH 200K	BO-ALTH 200K	LO-ALTH 200K-ST	200	50	800	ball bearing	245	140 x 110	105 x 75–80	11	60
LO-ALTH 200K-CO	BO-ALTH 200K-CO	LO-ALTH 200K-ST-CO	200	50	800	ball bearing	245	140 x 110	105 x 75–80	11	60
LO-ALTH 202K *	BO-ALTH 202K *	LO-ALTH 202K-ST *	200	50	1,000	ball bearing	245	140 x 110	105 x 75–80	11	60
LO-ALTH 250K	BO-ALTH 250K	LO-ALTH 250K-ST	250	60	1,000	ball bearing	295	140 x 110	105 x 75–80	11	70
LO-ALTH 252K *	BO-ALTH 252K *	LO-ALTH 252K-ST *	250	60	1,200	ball bearing	295	140 x 110	105 x 75–80	11	70

* Heavy-duty wheel version

Versions / options



	version with extremely crowned tread	version with heavy duty wheel centre, reinforced design	antistatic version, non-marking grey	with directional lock 4 x 90°	with steel foot guard	truck lock
Technical description page	55		50	115	116	114
Product code suffix	-CO		-AS	-RI4	-FS	FF 125 / 150 / 160 / 200
Available for			all	wheel Ø 125–200 mm	upon request	wheel Ø 125–200 mm

SETH series

Heavy-duty wheels
with **Blickle Extrathane®** polyurethane tread,
with **welded steel wheel centre**



500–1,350 kg

Tread and tyre hardness

92 Shore A

Smooth operation / floor preservation

good

Rolling resistance

very good

Wear resistance

excellent



Tread:

- high-quality polyurethane elastomer Blickle Extrathane®, hardness 92 Shore A
- low rolling resistance
- high abrasion resistance
- high cut and tear propagation resistance
- colour light brown, non-marking, non-staining
- excellent chemical connection with the wheel centre

Wheel centre:

- thick-walled pressed steel, triple welded
- with welded tubular steel hub
- resistant to dirt, impact and shocks
- lacquered, colour silver

Other features:

- high chemical resistance to many aggressive substances
- operating temperature: -20 °C to +70 °C, temporarily up to +90 °C, reduced load capacity over +40 °C

Additional details:

- wheel series: page 66
- tread: page 55
- bearing types: page 84–85
- chemical resistance: page 51

Wheels	Wheel Ø	Wheel width	Load capacity at 4 km/h	Load capacity at 10 km/h	Bearing type	Axle bore Ø	Hub length
	(D) [mm]	(T2) [mm]	[kg]	[kg]		(d) [mm]	(T1) [mm]
SETH 125/20K	125	50	500	250	ball bearing	20	60
SETH 150/20K	150	50	650	320	ball bearing	20	60
SETH 150/25K	150	50	650	320	ball bearing	25	60
SETH 160/20K	160	50	700	350	ball bearing	20	60
SETH 160/25K	160	50	700	350	ball bearing	25	60
SETH 200/20K	200	50	1,000	500	ball bearing	20	60
SETH 200/25K	200	50	1,000	500	ball bearing	25	60
SETH 250/25K	250	60	1,350	670	ball bearing	25	70

5

Versions / options



with grease nipple other shore hardnesses and special colours

Technical description page

Product code suffix **-NI**

Available for upon request upon request

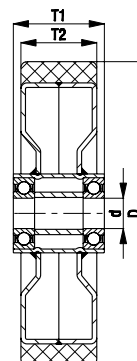

LH-SETH, BH-SETH series

Pressed steel castors, heavy-duty design, with top plate, wheel with Blickle Extrathane® polyurethane tread

500–900 kg

Bracket: LH/BH series

- strong pressed steel, zinc-plated, blue-passivated, Cr6-free
- heavy fork and top plate

Swivel bracket:

- double ball bearing in the swivel head
- bolted and secured central kingpin, extremely strong
- particularly resistant to shocks and impact due to **four specially-shaped, hardened bearing seats**

Wheel: SETH series

- tread: high-quality polyurethane elastomer Blickle Extrathane®, hardness 92 Shore A, colour light brown, non-marking, non-staining
- wheel centre: thick-walled pressed steel, triple welded, with tubular steel hub, lacquered, colour silver

Additional details:

- bracket series: page 92
- brakes: page 112–113
- wheel series: page 282
- bearing types: page 84–85

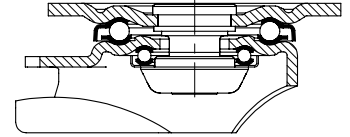

5

Swivel castors	Fixed castors	Swivel castors with "stop-fix" brake	Wheel Ø [mm]	Wheel width [mm]	Load capacity [kg]	Bearing type	Total height [mm]	Plate size [mm]	Bolt hole spacing [mm]	Bolt hole Ø [mm]	Offset swivel castor [mm]
LH-SETH 125K	BH-SETH 125K	LH-SETH 125K-FI	125	50	500	ball bearing	170	140 x 110	105 x 75–80	11	55
LH-SETH 150K	BH-SETH 150K	LH-SETH 150K-FI	150	50	650	ball bearing	197	140 x 110	105 x 75–80	11	65
LH-SETH 160K	BH-SETH 160K	LH-SETH 160K-FI	160	50	700	ball bearing	202	140 x 110	105 x 75–80	11	65
LH-SETH 200K	BH-SETH 200K	LH-SETH 200K-FI	200	50	900	ball bearing	245	140 x 110	105 x 75–80	11	70
LH-SETH 250K	BH-SETH 250K	*	250	60	900	ball bearing	295	140 x 110	105 x 75–80	11	82

* "stop-top" brake version, see versions / options

Versions / options



	with "stop-top" brake	with "ideal-stop" brake total height +17 mm	directional lock (separate) 1 x 360°	with steel foot guard	truck lock
Technical description page	112	112	115	116	114
Product code suffix	-ST	-IS	RI-05.03	-FS	FF 125 / 150 / 160 / 200
Available for	all	wheel Ø 160–200 mm**	wheel Ø 125–200 mm***	all	wheel Ø 125–200 mm

** Synthetic adapter plate to balance out total height for swivel and fixed castors without "ideal-stop" brake: **product code AP3-17**

*** Only for swivel castors without brake or swivel castor with "stop-top" brake upon request

LO-SETH, BO-SETH series

**Welded steel heavy-duty castors,
wheel with polyurethane tread
Blickle Extrathane®**

500–1,200 kg

Bracket: LO/BO series

- solid welded steel construction, zinc-plated, blue-passivated, Cr6-free

Swivel bracket:

- double ball bearing in the swivel head
- **four specially-shaped, hardened bearing seats** for additional strength
- bolted and secured welded central kingpin, extremely strong
- swivel head seal with labyrinth design
- grease nipple

Wheel: SETH series

- tread: high-quality polyurethane elastomer Blickle Extrathane®, hardness 92 Shore A, colour light brown, non-marking, non-staining
- wheel centre: thick-walled pressed steel, triple welded, with tubular steel hub, lacquered, colour silver

Additional details:

- bracket series: page 93
- brakes: page 112–113
- wheel series: page 282
- bearing types: page 84–85



5

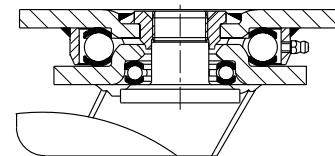

Swivel castors	Fixed castors	Swivel castor with "stop-top" brake	Wheel Ø [mm]	Wheel width [mm]	Load capacity [kg]	Bearing type	Total height [mm]	Plate size [mm]	Bolt hole spacing [mm]	Bolt hole Ø [mm]	Offset swivel castor [mm]
LO-SETH 125K	BO-SETH 125K	LO-SETH 125K-ST	125	50	500	ball bearing	170	140 x 110	105 x 75–80	11	50
LO-SETH 150K	BO-SETH 150K	LO-SETH 150K-ST	150	50	650	ball bearing	200	140 x 110	105 x 75–80	11	55
LO-SETH 160K	BO-SETH 160K	LO-SETH 160K-ST	160	50	700	ball bearing	205	140 x 110	105 x 75–80	11	55
LO-SETH 200K	BO-SETH 200K	LO-SETH 200K-ST	200	50	1,000	ball bearing	245	140 x 110	105 x 75–80	11	60
LO-SETH 250K	BO-SETH 250K	LO-SETH 250K-ST	250	60	1,200	ball bearing	295	140 x 110	105 x 75–80	11	70

Versions / options



	with directional lock 4 x 90°	with steel foot guard	truck lock
Technical description page	115	116	114
Product code suffix	-R14	-FS	FF 125 / 150 / 160 / 200
Available for	wheel Ø 125–200 mm	upon request	wheel Ø 125–200 mm

LS-SETH, BS-SETH series

**Welded steel heavy-duty castors,
heavy-duty swivel head, wheel with
Blickle Extrathane® polyurethane tread**

500–1,350 kg

Bracket: LS/BS series

- particularly robust welded steel construction, zinc-plated, yellow-passivated, Cr6-free

Swivel bracket:

- axial grooved ball bearing ISO 104 and tapered roller bearing ISO 355 in the swivel head
- bolted and secured welded central kingpin, extremely strong
- dust and splash-proof
- grease nipple

Wheel: SETH series

- tread: high-quality polyurethane elastomer Blickle Extrathane®, hardness 92 Shore A, colour light brown, non-marking, non-staining
- wheel centre: thick-walled pressed steel, triple welded, with tubular steel hub, lacquered, colour silver

Additional details:

- bracket series: page 94
- brakes: page 112–113
- wheel series: page 282
- bearing types: page 84–85

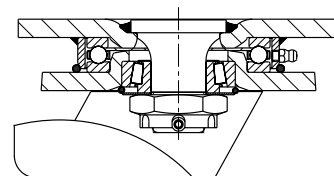

5

Swivel castors	Fixed castors	Swivel castor with "stop-top" brake	Wheel Ø [mm]	Wheel width [mm]	Load capacity [kg]	Bearing type	Total height [mm]	Plate size [mm]	Bolt hole spacing [mm]	Bolt hole Ø [mm]	Offset swivel castor [mm]
LS-SETH 125K	BS-SETH 125K	LS-SETH 125K-ST	125	50	500	ball bearing	170	140 x 110	105 x 75–80	11	50
LS-SETH 150K	BS-SETH 150K	LS-SETH 150K-ST	150	50	650	ball bearing	200	140 x 110	105 x 75–80	11	55
LS-SETH 160K	BS-SETH 160K	LS-SETH 160K-ST	160	50	700	ball bearing	205	140 x 110	105 x 75–80	11	55
LS-SETH 200K	BS-SETH 200K	LS-SETH 200K-ST	200	50	1,000	ball bearing	245	140 x 110	105 x 75–80	11	60
LS-SETH 250K	BS-SETH 250K	LS-SETH 250K-ST	250	60	1,350	ball bearing	305	175 x 140	140 x 105	14	75

Versions / options



	with directional lock 4 x 90°	with steel foot guard	truck lock
Technical description page	115	116	114
Product code suffix	-R14	-FS	FF 125 / 150 / 160 / 200
Available for	all	all	wheel Ø 125–200 mm

VSTH, GTH series, wheel Ø 35–200 mm

Heavy-duty wheels
with **Blickle Extrathane®** polyurethane tread,
with steel or cast iron wheel centre



100–1,600 kg

Tread and tyre hardness

92 Shore A

Smooth operation / floor preservation

good

Rolling resistance

very good

Wear resistance

excellent



Tread:

- high-quality polyurethane elastomer Blickle Extrathane®, hardness 92 Shore A
- low rolling resistance
- high abrasion resistance
- high cut and tear propagation resistance
- colour light brown, non-marking, non-staining
- excellent chemical connection with the wheel centre

Wheel centre:

- series VSTH: steel
- series GTH: rugged grey cast iron, with grease nipple from wheel Ø 150 mm, lacquered, colour silver

Other features:

- high chemical resistance to many aggressive substances
- operating temperature: -20 °C to +70 °C, temporarily up to +90 °C, reduced load capacity over +40 °C

Additional details:

- wheel series: page 66
- tread: page 55
- bearing types: page 84–85
- chemical resistance: page 51

Wheels	Wheel Ø (D) [mm]	Wheel width (T2) [mm]	Load capacity at 4 km/h [kg]	Load capacity at 10 km/h [kg]	Bearing type	Axle bore Ø (d) [mm]	Hub length (T1) [mm]
VSTH 35/6K	35	27	100	–	ball bearing	6	30
VSTH 50/8K	50	33	150	–	ball bearing	8	36
VSTH 60/15K	60	35	200	–	ball bearing	15	35
VSTH 62/10K	60	60	320	–	ball bearing	10	60
VSTH 65/15K	65	40	250	–	ball bearing	15	40
VSTH 75/20K	75	40	270	–	ball bearing	20	40
VSTH 80/20K	80	40	280	–	ball bearing	20	40
VSTH 82/20K	80	70	500	–	ball bearing	20	70
GTH 100/15K	100	40	450	–	ball bearing	15	40
GTH 101/20-50K	100	50	600	–	ball bearing	20	50
GTH 101/20K	100	50	600	–	ball bearing	20	60
GTH 125/15K	125	40	550	–	ball bearing	15	45
GTH 127/20-50K	125	50	700	350	ball bearing	20	50
GTH 127/20K	125	50	700	350	ball bearing	20	60
GTH 127/25-50K	125	50	700	350	ball bearing	25	50
GTH 140/20K	140	54	900	450	ball bearing	20	60
GTH 150/20-50K	150	50	800	400	ball bearing	20	50
GTH 150/20K	150	50	800	400	ball bearing	20	60
GTH 160/20K	160	50	800	400	ball bearing	20	60
GTH 160/25K	160	50	800	400	ball bearing	25	60
GTH 175/20K	175	50	875	430	ball bearing	20	60
GTH 175/25K	175	50	875	430	ball bearing	25	60
GTH 177/25K	175	80	1,300	650	ball bearing	25	80
GTH 181/25K	180	40	800	400	ball bearing	25	40
GTH 182/25K	180	65	1,100	550	ball bearing	25	75
GTH 200/20K	200	50	1,000	500	ball bearing	20	60
GTH 200/25K	200	50	1,000	500	ball bearing	25	60
GTH 201/25K	200	60	1,400	700	ball bearing	25	60
GTH 202/25K	200	80	1,600	800	ball bearing	25	90
GTH 202/30K	200	80	1,600	800	ball bearing	30	90
GTH 202/35K	200	80	1,600	800	ball bearing	35	90

For other wheel Ø, see next page

Versions / options

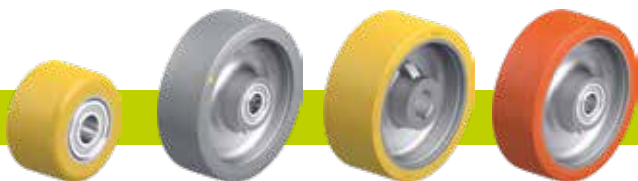
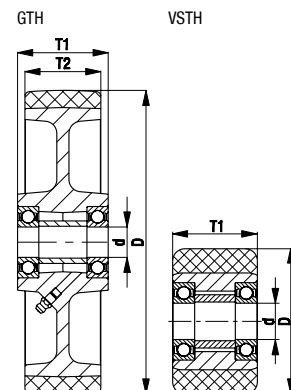

image VSTH	antistatic version, non-marking grey	drive wheels with hub keyway	other shore hardnesses and special colours
Technical description page	50	75	
Product code suffix	-AS	GTHN series	
Available for	upon request	see page 541–542	



GTH series, wheel Ø 250–1,000 mm

Heavy-duty wheels
with **Blickle Extrathane®** polyurethane tread,
with **cast iron wheel centre**



1,250–30,000 kg

Tread and tyre hardness
 92 Shore A

Smooth operation / floor preservation
 good

Rolling resistance
 very good

Wear resistance
 excellent



Tread:

- high-quality polyurethane elastomer Blickle Extrathane®, hardness 92 Shore A
- low rolling resistance
- high abrasion resistance
- high cut and tear propagation resistance
- colour light brown, non-marking, non-staining
- excellent chemical connection with the wheel centre

Wheel centre:

- rugged grey cast iron
- with grease nipple
- lacquered, colour silver

Other features:

- high chemical resistance to many aggressive substances
- operating temperature: -20 °C to +70 °C, temporarily up to +90 °C, reduced load capacity over +40 °C

Additional details:

- wheel series: page 66
- tread: page 55
- bearing types: page 84–85
- chemical resistance: page 51

Wheels	Wheel Ø	Wheel width	Load capacity at 4 km/h	Load capacity at 10 km/h	Bearing type	Axle bore Ø	Hub length
	(D) [mm]	(T2) [mm]	[kg]	[kg]		(d) [mm]	(T1) [mm]
GTH 251/25K	250	50	1,250	620	ball bearing	25	60
GTH 251/30K	250	50	1,250	620	ball bearing	30	60
GTH 250/25K	250	60	1,500	750	ball bearing	25	70
GTH 250/30K	250	60	1,500	750	ball bearing	30	70
GTH 250/30K-01	250	60	1,750	870	ball bearing	30	70
GTH 250/35K	250	60	1,500	750	ball bearing	35	70
GTH 252/25K	250	80	1,800	900	ball bearing	25	90
GTH 252/30K	250	80	2,200	1,100	ball bearing	30	90
GTH 254/40K	250	130	3,150	1,550	ball bearing	40	140
GTH 301/25K	300	45	1,300	650	ball bearing	25	60
GTH 300/30K	300	60	1,800	900	ball bearing	30	70
GTH 302/30K	300	80	2,400	1,200	ball bearing	30	90
GTH 302/35K	300	80	2,400	1,200	ball bearing	35	90
GTH 304/35K	300	100	3,000	1,500	ball bearing	35	120
GTH 360/40K	360	75	2,500	1,250	ball bearing	40	90
GTH 362/40K	360	80	3,000	1,500	ball bearing	40	90
GTH 363/40K	360	100	3,600	1,800	ball bearing	40	100
GTH 364/40K	360	120	3,800	1,900	ball bearing	40	120
GTH 400/35K	400	60	2,400	1,200	ball bearing	35	75
GTH 402/40K	400	80	3,000	1,500	ball bearing	40	90
GTH 404/40K	400	100	3,800	1,900	ball bearing	40	120
GTH 406/50K	400	125	5,000	2,500	ball bearing	50	125
GTH 500/50K	500	100	5,000	2,500	ball bearing	50	100
GTH 504/60K	500	150	7,500	3,750	ball bearing	60	150
GTH 506/80K	500	200	10,000	5,000	ball bearing	80	200
GTH 602/80K	600	150	9,000	4,500	ball bearing	80	150
GTH 604/80K	600	200	12,000	6,000	ball bearing	80	200
GTH 750/120K	750	200	15,000	7,500	ball bearing	120	200
GTH 1000/160PR	1,000	300	30,000	15,000	spherical roller bearing	160	330

Other dimensions available upon request

5

Versions / options



	antistatic version, non-marking grey	drive wheels with hub keyway	other shore hardnesses and special colours
Technical description page	50	75	
Product code suffix	-AS	GTHN series	
Available for	upon request	see page 541–542	upon request

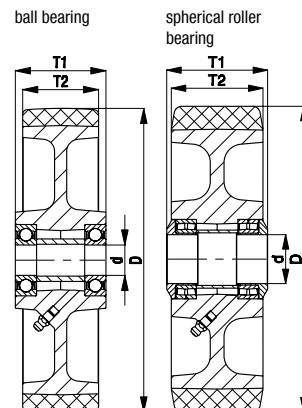

LH-VSTH, BH-VSTH, LH-GTH, BH-GTH series

Pressed steel castors, heavy-duty design, with top plate, wheel with Blickle Extrathane® polyurethane tread



280–900 kg

Bracket: LH/BH series

- strong pressed steel, zinc-plated, blue-passivated, Cr6-free
- heavy fork and top plate

Swivel bracket:

- double ball bearing in the swivel head
- bolted and secured central kingpin, extremely strong
- particularly resistant to shocks and impact due to **four specially-shaped, hardened bearing seats**

Wheel: VSTH/GTH series

- tread: high-quality polyurethane elastomer Blickle Extrathane®, hardness 92 Shore A, colour light brown, non-marking, non-staining
- wheel centre: VSTH series: steel
GTH series: rugged grey cast iron, with grease nipple from wheel Ø 150 mm, lacquered, colour silver

Additional details:

- bracket series: page 92
- brakes: page 112–113
- wheel series: page 286–287
- bearing types: page 84–85



5

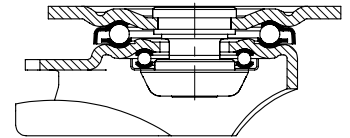

Swivel castors	Fixed castors	Swivel castors with "stop-fix" brake	Wheel Ø [mm]	Wheel width [mm]	Load capacity [kg]	Bearing type	Total height [mm]	Plate size [mm]	Bolt hole spacing [mm]	Bolt hole Ø [mm]	Offset swivel castor [mm]
LH-VSTH 62K			60	60	320	ball bearing	92	100 x 85	80 x 60	9	45
LH-VSTH 80K	BH-VSTH 80K	LH-VSTH 80K-FI	80	40	280	ball bearing	120	100 x 85	80 x 60	9	45
LH-VSTH 82K			80	70	500	ball bearing	112	100 x 85	80 x 60	9	45
LH-GTH 100K-1	BH-GTH 100K-1	LH-GTH 100K-1-FI	100	40	450	ball bearing	140	100 x 85	80 x 60	9	45
LH-GTH 100K-3	BH-GTH 100K-3	LH-GTH 100K-3-FI	100	40	450	ball bearing	140	140 x 110	105 x 75–80	11	45
LH-GTH 125K-1	BH-GTH 125K-1	LH-GTH 125K-1-FI	125	40	550	ball bearing	165	100 x 85	80 x 60	9	45
LH-GTH 125K-3	BH-GTH 125K-3	LH-GTH 125K-3-FI	125	40	550	ball bearing	165	140 x 110	105 x 75–80	11	45
LH-GTH 127K	BH-GTH 127K	LH-GTH 127K-FI	125	50	700	ball bearing	170	140 x 110	105 x 75–80	11	55
LH-GTH 150K	BH-GTH 150K	LH-GTH 150K-FI	150	50	800	ball bearing	197	140 x 110	105 x 75–80	11	65
LH-GTH 160K	BH-GTH 160K	LH-GTH 160K-FI	160	50	800	ball bearing	202	140 x 110	105 x 75–80	11	65
LH-GTH 175K	BH-GTH 175K	LH-GTH 175K-FI	175	50	875	ball bearing	220	140 x 110	105 x 75–80	11	67
LH-GTH 200K	BH-GTH 200K	LH-GTH 200K-FI	200	50	900	ball bearing	245	140 x 110	105 x 75–80	11	70
LH-GTH 202K	BO-GTH 202K *	**	200	80	800	ball bearing	245	140 x 110	105 x 75–80	11	70
LH-GTH 250K	BH-GTH 250K	**	250	60	900	ball bearing	295	140 x 110	105 x 75–80	11	82

* Welded steel construction

** "stop-top" brake version, see versions / options

Versions / options



	antistatic version, non-marking grey	with "stop-top" brake	with "central-stop" central brake system	with "ideal-stop" brake total height +17 mm	with directional lock (separate) 1x 360°	with steel foot guard	truck lock
Technical description page	50	112	113	112	115	116	114
Product code suffix	-AS	-ST	-CS13	-IS	see ****	-FS	FF 125 / 150 / 160 / 200
Available for	upon request	wheel Ø 80x40, 100–250 mm	wheel Ø 160, 200x50 mm	wheel Ø 160+200 mm***	for wheel Ø and plate dimensions, see****	wheel Ø 100–250 mm	wheel Ø 125x50–200 mm

*** Synthetic adapter plate to balance out total height for swivel and fixed castors without "ideal-stop" brake: **product code AP3-17**

**** **RI-04.01** for wheel Ø 80x40, 100, 125 mm with plate 100x85 mm, **RI-04.03** for wheel Ø 100–125x40 mm with plate 140x110 mm, **RI-05.03** for wheel Ø 125x50–200x50 mm (Only for swivel castors without brake or swivel castor with "stop-top" and "central-stop" brake upon request)

LUH-GTH, BH-GTH series

Pressed steel castors, heavy-duty design, enclosed, with top plate, wheel with Blickle Extrathane® polyurethane tread



700–1,000 kg

Bracket: LUH/BH series

- strong pressed steel, zinc-plated, blue-passivated, Cr6-free

Swivel bracket:

- four-point ball bearing for extremely heavy loads
- enclosed and sealed swivel head
- particularly resistant to shocks and impact due to **specially-shaped, hardened bearing seats**

Wheel: GTH series

- tread: high-quality polyurethane elastomer Blickle Extrathane®, hardness 92 Shore A, colour light brown, non-marking, non-staining
- wheel centre: rugged grey cast iron, with grease nipple from wheel Ø 150 mm, lacquered, colour silver

Additional details:

- bracket series: page 93
- brakes: page 112–113
- wheel series: page 286
- bearing types: page 84–85

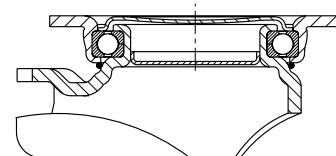

5

Swivel castors	Fixed castors	Swivel castors with "stop-fix" brake	Wheel Ø [mm]	Wheel width [mm]	Load capacity [kg]	Bearing type	Total height [mm]	Plate size [mm]	Bolt hole spacing [mm]	Bolt hole Ø [mm]	Offset swivel castor [mm]
LUH-GTH 127K	BH-GTH 127K	LUH-GTH 127K-FI	125	50	700	ball bearing	170	140 x 110	105 x 75–80	11	55
LUH-GTH 150K	BH-GTH 150K	LUH-GTH 150K-FI	150	50	800	ball bearing	197	140 x 110	105 x 75–80	11	61
LUH-GTH 160K	BH-GTH 160K	LUH-GTH 160K-FI	160	50	800	ball bearing	202	140 x 110	105 x 75–80	11	61
LUH-GTH 200K	BH-GTH 200K	LUH-GTH 200K-FI	200	50	1,000	ball bearing	245	140 x 110	105 x 75–80	11	63

Versions / options



	antistatic version, non-marking grey	directional lock (separate) 1 x 360°	with steel foot guard
Technical description page	50	115	116
Product code suffix	-AS	RI-05.03	-FS
Available for	upon request	all*	upon request

* Only for swivel castors without brake

LO-GTH, BO-GTH series

**Welded steel heavy-duty castors,
wheel with polyurethane tread
Blickle Extrathane®**



700–1,250 kg

Bracket: LO/BO series

- solid welded steel construction, zinc-plated, blue-passivated, Cr6-free

Swivel bracket:

- double ball bearing in the swivel head
- **four specially-shaped, hardened bearing seats** for additional strength
- bolted and secured welded central kingpin, extremely strong
- swivel head seal with labyrinth design
- grease nipple

Wheel: GTH series

- tread: high-quality polyurethane elastomer Blickle Extrathane®, hardness 92 Shore A, colour light brown, non-marking, non-staining
- wheel centre: rugged grey cast iron, with grease nipple from wheel Ø 150 mm, lacquered, colour silver

Additional details:

- bracket series: page 93
- brakes: page 112–113
- wheel series: page 286–287
- bearing types: page 84–85



5

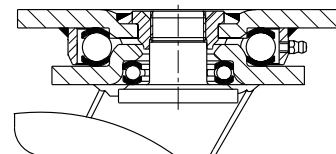

Swivel castors	Fixed castors	Swivel castor with "stop-top" brake	Wheel Ø [mm]	Wheel width [mm]	Load capacity [kg]	Bearing type	Total height [mm]	Plate size [mm]	Bolt hole spacing [mm]	Bolt hole Ø [mm]	Offset swivel castor [mm]
LO-GTH 127K	BO-GTH 127K	LO-GTH 127K-ST	125	50	700	ball bearing	170	140 x 110	105 x 75–80	11	50
LO-GTH 150K	BO-GTH 150K	LO-GTH 150K-ST	150	50	800	ball bearing	200	140 x 110	105 x 75–80	11	55
LO-GTH 160K	BO-GTH 160K	LO-GTH 160K-ST	160	50	800	ball bearing	205	140 x 110	105 x 75–80	11	55
LO-GTH 200K	BO-GTH 200K	LO-GTH 200K-ST	200	50	1,000	ball bearing	245	140 x 110	105 x 75–80	11	60
LO-GTH 201K	BO-GTH 201K	LO-GTH 201K-ST	200	60	1,250	ball bearing	245	140 x 110	105 x 75–80	11	60
LO-GTH 202K	BO-GTH 202K	LO-GTH 202K-ST	200	80	1,100	ball bearing	245	140 x 110	105 x 75–80	11	65
LO-GTH 251K	BO-GTH 251K	LO-GTH 251K-ST	250	50	1,200	ball bearing	295	140 x 110	105 x 75–80	11	70
LO-GTH 250K	BO-GTH 250K	LO-GTH 250K-ST	250	60	1,200	ball bearing	295	140 x 110	105 x 75–80	11	70

Versions / options



	antistatic version, non-marking grey	with directional lock 4 x 90°	with steel foot guard	truck lock
Technical description page	50	115	116	114
Product code suffix	-AS	-RI4	-FS	FF 125 / 150 / 160 / 200
Available for	upon request	wheel Ø 125–200x60 mm	upon request	wheel Ø 125–200 mm

LS-GTH, BS-GTH series

Welded steel heavy-duty castors, heavy-duty swivel head, wheel with Blickle Extrathane® polyurethane tread



700–12,000 kg

Bracket: LS/BS series

- particularly robust welded steel construction, zinc-plated, yellow-passivated, Cr6-free
- Swivel bracket:
 - axial grooved ball bearing ISO 104 and tapered roller bearing ISO 355 in the swivel head
 - bolted and secured welded central kingpin, extremely strong
 - dust and splash-proof
 - grease nipple

Wheel: GTH series

- tread: high-quality polyurethane elastomer Blickle Extrathane®, hardness 92 Shore A, colour light brown, non-marking, non-staining
- wheel centre: rugged grey cast iron, with grease nipple from wheel Ø 150 mm, lacquered, colour silver

Additional details:

- bracket series: page 94
- brakes: page 112–113
- wheel series: page 286–287
- bearing types: page 84–85

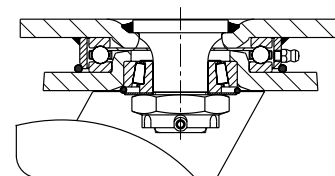

5

Swivel castors	Fixed castors	Swivel castor with "stop-top" brake	Wheel Ø [mm]	Wheel width [mm]	Load capacity [kg]	Bearing type	Total height [mm]	Plate size [mm]	Bolt hole spacing [mm]	Bolt hole Ø [mm]	Offset swivel castor [mm]
LS-GTH 127K	BS-GTH 127K	LS-GTH 127K-ST	125	50	700	ball bearing	170	140 x 110	105 x 75–80	11	50
LS-GTH 150K	BS-GTH 150K	LS-GTH 150K-ST	150	50	800	ball bearing	200	140 x 110	105 x 75–80	11	55
LS-GTH 160K	BS-GTH 160K	LS-GTH 160K-ST	160	50	800	ball bearing	205	140 x 110	105 x 75–80	11	55
LS-GTH 200K	BS-GTH 200K	LS-GTH 200K-ST	200	50	1,000	ball bearing	245	140 x 110	105 x 75–80	11	60
LS-GTH 201K	BS-GTH 201K	LS-GTH 201K-ST	200	60	1,400	ball bearing	245	140 x 110	105 x 75–80	11	60
LS-GTH 202K	BS-GTH 202K	LS-GTH 202K-ST	200	80	1,600	ball bearing	255	175 x 140	140 x 105	14	65
LS-GTH 250K	BS-GTH 250K	LS-GTH 250K-ST	250	60	1,500	ball bearing	305	175 x 140	140 x 105	14	75
LS-GTH 252K	BS-GTH 252K	LS-GTH 252K-ST	250	80	1,800	ball bearing	305	175 x 140	140 x 105	14	75
LS-GTH 300K	BS-GTH 300K	LS-GTH 300K-ST	300	60	1,800	ball bearing	355	175 x 140	140 x 105	14	85
LS-GTH 302K	BS-GTH 302K	LS-GTH 302K-ST	300	80	2,400	ball bearing	355	175 x 140	140 x 105	14	85
LS-GTH 304K	BS-GTH 304K	*	300	100	3,000	ball bearing	370	200 x 160	160 x 120	14	85
LS-GTH 360K	BS-GTH 360K	*	360	75	2,500	ball bearing	430	200 x 160	160 x 120	14	100
LS-GTH 364K	BS-GTH 364K	*	360	120	3,800	ball bearing	430	255 x 200	210 x 160	18	100
LS-GTH 402K	BS-GTH 402K	*	400	80	3,000	ball bearing	470	200 x 160	160 x 120	14	100
LS-GTH 406K	BS-GTH 406K	*	400	125	5,000	ball bearing	480	255 x 200	210 x 160	18	125
LS-GTH 504K	BS-GTH 504K	*	500	150	7,500	ball bearing	630	400 x 300	340 x 240	26	125
LS-GTH 604K	BS-GTH 604K	*	600	200	12,000	ball bearing	730	400 x 300	340 x 240	26	130

* "Radstop" brake version

Versions / options



	antistatic version, non-marking grey	with "Radstop" wheel brake	with directional lock 4 x 90°	with directional lock 4 x 90° (inserted by hand)	with steel foot guard	truck lock
Technical description page	50	113	115	115	116	114
Product code suffix	-AS	-RAH	-RI4	-RI4H	-FS	FF 125 / 150 / 160 / 200
Available for	upon request	from wheel Ø 300x100 mm upon request	wheel Ø 125–300x80 mm	from wheel Ø 300x100 mm upon request	wheel Ø 125–250 mm	wheel Ø 125–200x60 mm

LOD-VSTH, -ALTH, -GTH, BOD-VSTH, -ALTH, -GTH series

**Welded steel twin wheel heavy-duty castors, wheels with polyurethane tread
Blickle Extrathane®**



500–900 kg

Bracket: LOD/BOD series

- solid welded steel construction, zinc-plated, blue-passivated, Cr6-free

Swivel bracket:

- double ball bearing in the swivel head
- **four specially-shaped, hardened bearing seats** for additional strength
- bolted and secured welded central kingpin, extremely strong
- swivel head seal with labyrinth design
- grease nipple

Wheel: VSTH/ALTH/GTH series

- tread: high-quality polyurethane elastomer Blickle Extrathane®, hardness 92 Shore A, colour light brown, non-marking, non-staining
- wheel centre: VSTH series: steel
ALTH series: die-cast aluminium
GTH series: rugged grey cast iron, lacquered, colour silver

Additional details:

- bracket series: page 93
- wheel series: page 274, 286
- bearing types: page 84–85



5

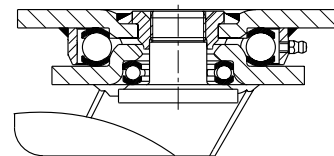

Swivel castors	Fixed castors	Wheel Ø [mm]	Wheel width [mm]	Load capacity [kg]	Bearing type	Total height [mm]	Plate size [mm]	Bolt hole spacing [mm]	Bolt hole Ø [mm]	Offset swivel castor [mm]
LOD-VSTH 75K	BOD-VSTH 75K	75	2 x 40	500	ball bearing	123	140 x 110	105 x 75–80	11	40
LOD-ALTH 101K	BOD-ALTH 101K	100	2 x 40	750	ball bearing	145	140 x 110	105 x 75–80	11	45
LOD-GTH 125K	BOD-GTH 125K	125	2 x 40	900	ball bearing	170	140 x 110	105 x 75–80	11	50

Fixed castors: long side of plate parallel to the wheel axle

Versions / options



	antistatic version, non-marking grey	with steel foot guard
Technical description page	50	116
Product code suffix	-AS	-FS
Available for	upon request	upon request

LSD-VSTH, BSD-VSTH, LSD-GTH, BSD-GTH series

Welded steel heavy-duty twin wheel castors, heavy-duty swivel head, wheels with Blickle Extrathane® polyurethane tread

520–12,000 kg

Bracket: LSD/BSD series

- particularly robust welded steel construction, zinc-plated, yellow-passivated, Cr6-free

Swivel bracket:

- axial grooved ball bearing ISO 104 and tapered roller bearing ISO 355 in the swivel head
- bolted and secured welded central kingpin, extremely strong
- dust and splash-proof
- grease nipple

Wheel: VSTH/GTH series

- tread: high-quality polyurethane elastomer Blickle Extrathane®, hardness 92 Shore A, colour light brown, non-marking, non-staining

wheel centre:

- VSTH series: steel
- GTH series: rugged grey cast iron, with grease nipple from wheel Ø 150 mm, lacquered, colour silver

Additional details:

- bracket series: page 94
- brakes: page 112–113
- wheel series: page 286–287
- bearing types: page 84–85

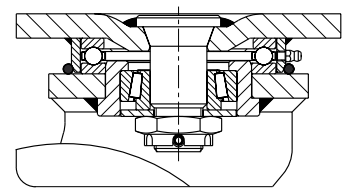

5

Swivel castors	Fixed castors	Wheel Ø [mm]	Wheel width [mm]	Load capacity [kg]	Bearing type	Total height [mm]	Plate size [mm]	Bolt hole spacing [mm]	Bolt hole Ø [mm]	Offset swivel castor [mm]
LSD-VSTH 80K	BSD-VSTH 80K	80	2 x 40	520	ball bearing	125	140 x 110	105 x 75–80	11	40
LSD-GTH 100K	BSD-GTH 100K	100	2 x 40	810	ball bearing	145	140 x 110	105 x 75–80	11	45
LSD-GTH 127K	BSD-GTH 127K	125	2 x 50	1,250	ball bearing	185	175 x 140	140 x 105	14	50
LSD-GTH 150K-35	BSD-GTH 150K-35	150	2 x 50	1,400	ball bearing	215	175 x 140	140 x 105	14	55
LSD-GTH 200K-35	BSD-GTH 200K-35	200	2 x 50	1,800	ball bearing	260	175 x 140	140 x 105	14	60
LSD-GTH 202K	BSD-GTH 202K	200	2 x 80	2,850	ball bearing	280	255 x 200	210 x 160	18	60
LSD-GTH 250K	BSD-GTH 250K	250	2 x 60	2,700	ball bearing	330	255 x 200	210 x 160	18	70
LSD-GTH 252K	BSD-GTH 252K	250	2 x 80	3,700	ball bearing	330	255 x 200	210 x 160	18	70
LSD-GTH 302K	BSD-GTH 302K	300	2 x 80	4,300	ball bearing	390	255 x 200	210 x 160	18	80
LSD-GTH 304K	BSD-GTH 304K	300	2 x 100	5,400	ball bearing	390	255 x 200	210 x 160	18	80
	BSD-GTH 304K	300	2 x 100	5,400	ball bearing	390	300 x 200	210 x 160	18	–
LSD-GTH 360K	BSD-GTH 360K	360	2 x 75	4,500	ball bearing	450	255 x 200	210 x 160	18	90
LSD-GTH 404K-42	BSD-GTH 404K-42	400	2 x 100	6,800	ball bearing	530	400 x 300	340 x 240	26	125
LSD-GTH 504K	BSD-GTH 504K	500	2 x 150	12,000	ball bearing	630	400 x 300	340 x 240	26	125

Fixed castors: long side of plate parallel to the wheel axle

Versions / options



	antistatic version, non-marking grey	with "Radstop" wheel brake	with "Radstop" wheel brake	with directional lock 4 x 90°	with directional lock 4 x 90° (inserted by hand)	with steel foot guard
Technical description page	50	113	113	115	115	116
Product code suffix	-AS	-RA	-RAH	-RI4	-RI4H	-FS
Available for	upon request	up to wheel Ø 200x50 mm upon request	from wheel Ø 200x80 mm upon request	wheel Ø 80–200x50 mm upon request	from wheel Ø 200x80 mm upon request	upon request