

Compact and levelling castors



12

Selection tool

Compact and levelling castors

Compact castors



Series	LRA / LKRA / LER / LR / LKR	LPA / LKPA / LE / L / LK	LH
	Compact castors		
	Single wheel castors		
Bracket description	pressed steel	pressed steel	strong pressed steel
Fitting type	bolt hole	top plate	top plate
Wheel Ø	35–65 mm	35–65 mm	60–80 mm
Castor load capacity up to	350 kg	350 kg	700 kg
Available wheel series	POA, POEV, VSTH, PO, GSPO	POA, POEV, VSTH, PO, GSPO	VSTH, SPO, GSPO, SVS
For a description of the wheel, refer to	page 143, 212, 286, 343, 368	page 143, 212, 286, 343, 368	page 286, 355, 368, 382
For information about swivel and fixed castors, refer to	page 496	page 497	page 498

12



LHD / LSD	LD
Compact castors	
Twin wheel castors	
pressed steel or welded steel	zinc die-cast
top plate	steel threaded pin
60–80 mm	50–60 mm
1,750 kg	250 kg
POEV, SE, ALTH, VSTH, ALST, ALBS, SPO, GSPO	POA, POEV, VSTH, PO
page 212, 228, 274, 286, 294, 319, 355, 368	page 143, 212, 286, 343
page 499	page 500



HRP / HRSP, HRIG	HRLH / HRLHD	HRLSD	HRLK...-HYD
Levelling castors			
	Wrench		Hydraulic pump
with additional adjustment wheel	with manually-adjustable truck lock	with adjustable mounting height	raise four levelling castors at the same time
–	optional	optional	–
45–90 mm	75 mm	125 mm	100 mm
2,000 kg	600 kg	1,300 kg	750 kg
2,000 kg	1,500 kg	3,000 kg	750 kg
■ ■ ■ ■ ■	■ ■ ■ ■ ■	■ ■ ■ ■ ■	■ ■ ■ ■ ■
✓	✓	✓	✓
–	–	✓	–
infrequent	infrequent	infrequent	frequent
page 505	page 506	page 507	page 508–509

Pressed steel compact castors with bolt hole

75–350 kg

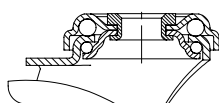

- Bracket:** LRA, LKRA, LER, LR, LKR series
- pressed steel, zinc-plated, blue-passivated, Cr6-free
 - double ball bearing in the swivel head
 - minimum swivel head play and smooth rolling characteristic and increased service life due to the special dynamic Blickle riveting process
 - bracket overview:
 - LRA series page 86
 - LKRA series page 86
 - LER series page 91
 - LR series page 91
 - LKR series page 92
 - brakes: page 112–113



- Wheel:** POEV series
- tyre: high-quality elastic solid rubber “Blickle EasyRoll” in smooth rolling quality, hardness 65 Shore A, colour black
 - wheel centre: high-quality nylon 6, impact resistant, colour black
 - detailed description: page 63, 212
- Wheel:** VSTH series
- tread: high-quality polyurethane elastomer Blickle Extrathane®, hardness 92 Shore A, colour light brown, non-marking, non-staining
 - wheel centre: steel
 - detailed description: page 66, 286
- Wheel:** POA series
- high-quality nylon 6, impact resistant, hardness 70 Shore D, colour black
 - detailed description: page 61, 143
- Wheel:** PO series
- high-quality nylon 6, impact resistant, hardness 70 Shore D, colour natural white
 - detailed description: page 69, 343
- Wheel:** GSPO series
- high-quality cast nylon, reaction-injected, impact resistant, hardness 80 Shore D, colour natural beige
 - detailed description: page 70, 368

12

Swivel castors	Swivel castors with “Radstop” brake	Wheel Ø [mm]	Wheel width [mm]	Load capacity at 3 km/h [kg]	Bearing type	Total height [mm]	Plate Ø [mm]	Bolt hole Ø [mm]	Offset swivel castor [mm]
LRA series									
LRA-POA 35G	LRA-POA 35G-RA	35	25	75	plain bore	50	43	11	15
LRA-VSTH 35K	LRA-VSTH 35K-RA	35	27	100	ball bearing	50	43	11	15
LRA-GSPO 35K	LRA-GSPO 35K-RA	35	28	100 *	ball bearing	50	43	11	15
LKRA series									
LKRA-POA 52G	LKRA-POA 52G-RA	50	29	120	plain bore	70	57	13	29
LKRA-GSPO 50K	LKRA-GSPO 50K-RA	50	32	150 *	ball bearing	70	57	13	29
LKRA-VSTH 50K	LKRA-VSTH 50K-RA	50	33	150	ball bearing	70	57	13	29
LER series									
LER-PO 60G	LER-PO 60G-RA	60	29	150	plain bore	80	70	13	35
LER-PO 60KF	LER-PO 60KF-RA	60	32	150	ball bearing (C)	80	70	13	35
LER-POEV 60KF	LER-POEV 60KF-RA	60	34	120	ball bearing (CC)	80	70	13	35
LR series									
LR-GSPO 60K	LR-GSPO 60K-RA	60	32	250 *	ball bearing	80	70	13	35
LR-VSTH 60K	LR-VSTH 60K-RA	60	35	200	ball bearing	80	70	13	35
LKR series									
LKR-GSPO 65K		65	40	350 *	ball bearing	88	88	13	41
LKR-VSTH 65K		65	40	250	ball bearing	88	88	13	41

* Test in compliance with DIN 12530 with extended breaks to avoid thermal overloading

Pressed steel compact castors with top plate

75–350 kg

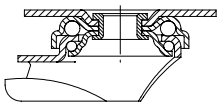

- Bracket:** LPA, LKPA, LE/B, L/B, LK/BK series
- pressed steel, zinc-plated, blue-passivated, Cr6-free
 - double ball bearing in the swivel head
 - minimum swivel head play and smooth rolling characteristic and increased service life due to the special dynamic Blickle riveting process
 - bracket overview:
 - series LPA page 86
 - series LKPA page 86
 - series LE/B page 90
 - series L/B page 91
 - series LK/BK page 92
 - brakes: page 112–113



- Wheel:** POEV series
- tyre: high-quality elastic solid rubber "Blickle EasyRoll" in smooth rolling quality, hardness 65 Shore A, colour black
 - wheel centre: high-quality nylon 6, impact resistant, colour black
 - detailed description: page 63, 212



- Wheel:** VSTH series
- tread: high-quality polyurethane elastomer Blickle Extrathane®, hardness 92 Shore A, colour light brown, non-marking, non-staining
 - wheel centre: steel
 - detailed description: page 66, 286



- Wheel:** POA series
- high-quality nylon 6, impact resistant, hardness 70 Shore D, colour black
 - detailed description: page 61, 143



- Wheel:** PO series
- high-quality nylon 6, impact resistant, hardness 70 Shore D, colour natural white
 - detailed description: page 69, 343



- Wheel:** GSPO series
- high-quality cast nylon, reaction-injected, impact resistant, hardness 80 Shore D, colour natural beige
 - detailed description: page 70, 368

Swivel castors	Fixed castors	Swivel castors with "Radstop" brake	Wheel Ø [mm]	Wheel width [mm]	Load capacity at 3 km/h [kg]	Bearing type	Total height [mm]	Plate size [mm]	Bolt hole spacing [mm]	Bolt hole Ø [mm]	Offset swivel castor [mm]
LPA series											
LPA-POA 35G		LPA-POA 35G-RA	35	25	75	plain bore	52	60 x 60	38 x 38 / 48 x 48	6.2	15
LPA-VSTH 35K		LPA-VSTH 35K-RA	35	27	100	ball bearing	52	60 x 60	38 x 38 / 48 x 48	6.2	15
LPA-GSPO 35K		LPA-GSPO 35K-RA	35	28	100 *	ball bearing	52	60 x 60	38 x 38 / 48 x 48	6.2	15
LKPA series											
LKPA-POA 52G		LKPA-POA 52G-RA	50	29	120	plain bore	73	90 x 66	75 x 45 / 61 x 51	8.5	29
LKPA-GSPO 50K		LKPA-GSPO 50K-RA	50	32	150 *	ball bearing	73	90 x 66	75 x 45 / 61 x 51	8.5	29
LKPA-VSTH 50K		LKPA-VSTH 50K-RA	50	33	150	ball bearing	73	90 x 66	75 x 45 / 61 x 51	8.5	29
LE series											
LE-PO 60G	B-PO 60G	LE-PO 60G-RA	60	29	150	plain bore	80	100 x 85	80 x 60	9	35
LE-PO 60KF	B-PO 60KF	LE-PO 60KF-RA	60	32	150	ball bearing (C)	80	100 x 85	80 x 60	9	35
LE-POEV 60KF	B-POEV 60KF	LE-POEV 60KF-RA	60	34	120	ball bearing (CC)	80	100 x 85	80 x 60	9	35
L series											
L-GSPO 60K	B-GSPO 60K	L-GSPO 60K-RA	60	32	250 *	ball bearing	80	100 x 85	80 x 60	9	35
L-VSTH 60K	B-VSTH 60K	L-VSTH 60K-RA	60	35	200	ball bearing	80	100 x 85	80 x 60	9	35
LK series											
LK-GSPO 65K	BK-GSPO 65K		65	40	350 *	ball bearing	90	100 x 85	80 x 60	9	40
LK-VSTH 65K	BK-VSTH 65K		65	40	250	ball bearing	90	100 x 85	80 x 60	9	40

* Test in compliance with DIN 12530 with extended breaks to avoid thermal overloading

Pressed steel compact castors, heavy-duty version, with top plate

280–700 kg

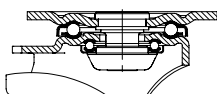

Bracket: LH/BH series

- strong pressed steel, zinc-plated, blue-passivated, Cr6-free
- heavy fork and top plate
- Swivel bracket:
 - double ball bearing in the swivel head
 - bolted and secured central kingpin, extremely strong
 - particularly resistant to shocks and impact due to **four specially-shaped, hardened bearing seats**
- bracket series: page 92
- brakes: page 112–113



Wheel: VSTH series

- tread: high-quality polyurethane elastomer Blickle Extrathane®, hardness 92 Shore A, colour light brown, non-marking, non-staining
- wheel centre: steel
- detailed description: page 66, 286



Wheel: SPO series

- high-quality nylon 6, impact resistant, hardness 70 Shore D, extremely robust heavy-duty version, colour natural white
- detailed description: page 69, 355



Wheel: GSPO series

- high-quality cast nylon, reaction-injected, impact resistant, hardness 80 Shore D, colour natural beige
- detailed description: page 70, 368



Wheel: SVS series

- heat-treatable steel, hardness 190–230 HB, slightly crowned tread
- detailed description: page 70, 382

12

Swivel castors	Fixed castors	Swivel castors with "stop-fix" brake	Wheel Ø [mm]	Wheel width [mm]	Load capacity at 3 km/h [kg]	Bearing type	Total height [mm]	Plate size [mm]	Bolt hole spacing [mm]	Bolt hole Ø [mm]	Offset swivel castor [mm]
LH / BH series											
LH-VSTH 62K			60	60	320	ball bearing	92	100 x 85	80 x 60	9	45
LH-GSPO 65K	BH-GSPO 65K		65	40	650 *	ball bearing	97	100 x 85	80 x 60	9	45
LH-SVS 65K	BH-SVS 65K		65	40	700	ball bearing	97	100 x 85	80 x 60	9	45
LH-SPO 75K	BH-SPO 75K	LH-SPO 75K-FI	75	32	300	ball bearing	118	100 x 85	80 x 60	9	45
LH-SPO 75G	BH-SPO 75G	LH-SPO 75G-FI	75	32	300	plain bore	118	100 x 85	80 x 60	9	45
LH-SPO 80K	BH-SPO 80K	LH-SPO 80K-FI	80	37	350	ball bearing	120	100 x 85	80 x 60	9	45
LH-GSPO 80K	BH-GSPO 80K	LH-GSPO 80K-FI	80	40	700 *	ball bearing	120	100 x 85	80 x 60	9	45
LH-SVS 80K	BH-SVS 80K		80	40	700	ball bearing	120	100 x 85	80 x 60	9	45
LH-VSTH 80K	BH-VSTH 80K	LH-VSTH 80K-FI	80	40	280	ball bearing	120	100 x 85	80 x 60	9	45
LH-SPO 82K			80	70	650	ball bearing	112	100 x 85	80 x 60	9	45
LH-VSTH 82K			80	70	500	ball bearing	112	100 x 85	80 x 60	9	45

* Load capacity test in compliance with DIN 12530 with extended breaks to avoid thermal overloading

Pressed steel or welded steel heavy-duty twin wheel compact castors, with top plate

210–1,750 kg

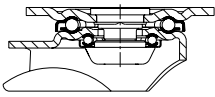

Bracket: LHD series

- strong pressed steel, zinc-plated, blue-passivated, Cr6-free (fixed bracket: solid welded steel construction)
- heavy fork and top plate
- double ball bearing in the swivel head
- bolted and secured central kingpin, extremely strong
- particularly resistant to shocks and impact due to **four specialy-shaped, hardened bearing seats**
- bracket series: page 93

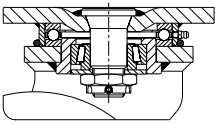

Bracket: LSD series

- particularly robust welded steel construction, zinc-plated, yellow-passivated, Cr6-free
- axial grooved ball bearing ISO 104 and tapered roller bearing ISO 355 in the swivel head
- bolted and secured welded central kingpin, extremely strong
- dust and splash-proof
- grease nipple
- bracket series: page 94



Wheel: POEV series

- tyre: high-quality elastic solid rubber "Blickle EasyRoll" in smooth rolling quality, hardness 65 Shore A, colour black
- wheel centre: high-quality nylon 6, impact resistant, colour black
- detailed description: page 63, 212



Wheel: SE series

- tyre: high-quality elastic solid rubber "Blickle EasyRoll" in smooth rolling quality, hardness 65 Shore A, colour black
- wheel centre: high-quality nylon 6, impact resistant, colour black
- detailed description: page 63, 228



Wheel: ALST series

- tread: high-quality polyurethane elastomer Blickle Softhane®, hardness 75 Shore A, colour green, non-marking, non-staining
- wheel centre: die-cast aluminium, colour silver grey
- detailed description: page 66, 294



Wheel: ALBS series

- tread: high-quality polyurethane elastomer Blickle Besthane® Soft, hardness 75 Shore A, colour blue, non-marking, non-staining
- wheel centre: die-cast aluminium, colour silver grey
- detailed description: page 68, 319



Wheel: ALTH, VSTH series

- tread: high-quality polyurethane elastomer Blickle Extrathane®, hardness 92 Shore A, colour light brown, non-marking, non-staining
- wheel centre: ALTH: die-cast aluminium, colour silver grey
VSTH: steel
- detailed description: page 65, 66, 274, 286



Wheel: SPO series

- high-quality nylon 6, impact resistant, hardness 70 Shore D, extremely robust heavy-duty version, colour natural white
- detailed description: page 69, 355



Wheel: GSPO series

- high-quality cast nylon, reaction-injected, impact resistant, hardness 80 Shore D, colour natural beige
- detailed description: page 70, 368

Swivel castors	Wheel Ø [mm]	Wheel width [mm]	Load capacity at 3 km/h [kg]	Bearing type	Total height [mm]	Plate size [mm]	Bolt hole spacing [mm]	Bolt hole Ø [mm]	Offset swivel castor [mm]
LHD series									
LHD-GSPO 60K	60	2 x 32	630 *	ball bearing	92	100 x 85	80 x 60	9	40
LHD-POEV 60KF	60	2 x 34	210	ball bearing (CC)	92	100 x 85	80 x 60	9	40
LHD-VSTH 60K	60	2 x 35	360	ball bearing	92	100 x 85	80 x 60	9	40
LHD-SPO 75K	75	2 x 32	540	ball bearing	110	100 x 85	80 x 60	9	45
LHD-ALST 80K	80	2 x 30	360	ball bearing	112	100 x 85	80 x 60	9	45
LHD-ALTH 80K	80	2 x 30	360	ball bearing	112	100 x 85	80 x 60	9	45
LHD-ALBS 80K	80	2 x 30	360	ball bearing	115	100 x 85	80 x 60	9	45
LHD-POEV 80KF	80	2 x 32	250	ball bearing (C)	112	100 x 85	80 x 60	9	45
LHD-VSTH 80K	80	2 x 40	500	ball bearing	115	140 x 110	105 x 75–80	11	45
LHD-SE 80K	80	2 x 45	360	ball bearing	115	140 x 110	105 x 75–80	11	45
LSD series									
LSD-GSPO 80K	80	2 x 40	1,750 *	ball bearing	125	140 x 110	105 x 75–80	11	40

* Test in compliance with DIN 12530 with extended breaks to avoid thermal overloading

Twin wheel compact castors

210–250 kg

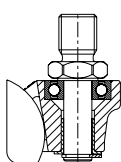

Bracket: LD series

- swivel bracket: zinc die-cast
- high-quality ball bearing in the swivel head
- zinc-plated steel threaded pin
- bracket series: page 99



Wheel: POEV series

- tyre: high-quality elastic solid rubber "Blickle EasyRoll" in smooth rolling quality, hardness 65 Shore A, colour black
- wheel centre: high-quality nylon 6, impact resistant, colour black
- detailed description: page 63, 212



Wheel: VSTH series

- tread: high-quality polyurethane elastomer Blickle Extrathane®, hardness 92 Shore A, colour light brown, non-marking, non-staining
- wheel centre: steel
- detailed description: page 66, 286



Wheel: POA series

- high-quality nylon 6, impact resistant, hardness 70 Shore D, colour black
- detailed description: page 61, 143



Wheel: PO series

- high-quality nylon 6, impact resistant, hardness 70 Shore D, colour natural white
- detailed description: page 69, 343

Swivel castors	Wheel Ø [mm]	Wheel width [mm]	Total castor width [mm]	Load capacity at 3 km/h [kg]	Bearing type	Total height [mm]	Threaded pin [mm]	Offset swivel castor [mm]
LD series								
LD-POA 52G	50	2 x 29	95	210	plain bore	56	M16 x 20	39
LD-VSTH 50K	50	2 x 33	100	250	ball bearing	56	M16 x 20	39
LD-PO 60G	60	2 x 29	105	250	plain bore	65	M16 x 20	39
LD-POEV 60KF	60	2 x 34	105	240	ball bearing (CC)	65	M16 x 20	39
LD-VSTH 60K	60	2 x 35	105	250	ball bearing	65	M16 x 20	39

HRLK series

Levelling castors with fixed operating lever and integrated truck lock, with top plate



170–300 kg

Bracket: HRLK series

- strong pressed steel, zinc-plated, blue-passivated, Cr6-free
- double ball bearing in the swivel head
- swivel head seal
- minimum swivel head play and smooth rolling characteristic and increased service life due to the special dynamic Blickle riveting process
- steel truck lock with rubber pad
- height adjustment with lever

Wheel:

POEV series

- tyre: high-quality elastic solid rubber "Blickle EasyRoll" in smooth rolling quality, hardness 65 Shore A, colour black
- wheel centre: high-quality nylon 6

ALST series

- tread: high-quality polyurethane elastomer Blickle Softhane®, hardness 75 Shore A, colour green
- wheel centre: die-cast aluminium

ALTH series

- tread: high-quality polyurethane elastomer Blickle Extrathane®, hardness 92 Shore A, colour light brown
- wheel centre: die-cast aluminium

PO series

- high-quality nylon 6, impact resistant, hardness 70 Shore D, colour natural white

SPO series

- high-quality nylon 6, impact resistant, hardness 70 Shore D, extremely robust heavy-duty version, colour natural white

Additional details:

- bracket series: page 99
- wheel series: page 63, 66, 65, 69
- bearing types: page 84–85

Swivel castors	Wheel Ø (D) [mm]	Wheel width [mm]	Load capacity [kg]	Bearing type	Total height (H) [mm]	Total height max. (h) [mm]	Stroke (T4) [mm]	Floor clearance foot max. (T3) [mm]	Plate size [mm]	Bolt hole spacing [mm]	Bolt hole Ø [mm]	Offset swivel castor [mm]
PO series												
HRLK-PO 75G	75	32	200	plain bore	118	120	2	13	100 x 85	80 x 60	9	56
HRLK-PO 82G	80	37	230	plain bore	120	122	2	13	100 x 85	80 x 60	9	56
HRLK-PO 100G	100	37	230	plain bore	140	142	2	13	100 x 85	80 x 60	9	65
HRLK-PO 100KA	100	37	230	ball bearing (C)	140	142	2	13	100 x 85	80 x 60	9	65
SPO series												
HRLK-SPO 75G	75	32	300	plain bore	118	120	2	13	100 x 85	80 x 60	9	56
HRLK-SPO 75K	75	32	300	ball bearing	118	120	2	13	100 x 85	80 x 60	9	56
HRLK-SPO 80K	80	37	300	ball bearing	120	122	2	13	100 x 85	80 x 60	9	56
POEV series												
HRLK-POEV 82KF	80	40	170	ball bearing (C)	120	122	2	13	100 x 85	80 x 60	9	56
HRLK-POEV 100KA	100	32	200	ball bearing (C)	140	142	2	13	100 x 85	80 x 60	9	65
ALST series												
HRLK-ALST 82K	80	40	230	ball bearing	120	122	2	13	100 x 85	80 x 60	9	56
HRLK-ALST 100K	100	40	230	ball bearing	140	142	2	13	100 x 85	80 x 60	9	65
ALTH series												
HRLK-ALTH 80K	80	30	180	ball bearing	120	122	2	13	100 x 85	80 x 60	9	56
HRLK-ALTH 100K	100	40	230	ball bearing	140	142	2	13	100 x 85	80 x 60	9	65

12

Versions / options *



	image POEV series	image ALST series	image ALTH series	with "central-stop" central brake system
Technical description page	63	66	65	113
Product code suffix				-CS13
Available for				upon request

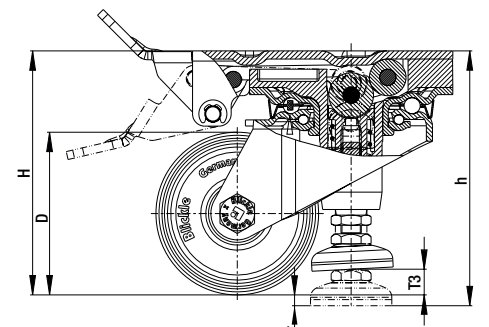

* **Other versions / options:** 1. corrosion-resistant version (product code **HRLKX-...**) upon request 2. electrically conductive version, wheel non-marking grey (product code suffix **-EL**) PO, SPO series upon request 3. antistatic version, wheel non-marking (product code suffix **-AS**) ALTH, ALST series upon request 4. synthetic adapter plate (+10 mm) to balance out total height for corresponding swivel and fixed castors: **Product code AP1-10**

HRLK...-HN series

Levelling castors with swiveling operating and release lever, with top plate



180–250 kg

Bracket: HRLK...-HN series

- strong pressed steel, zinc-plated, blue-passivated, Cr6-free
- double ball bearing in the swivel head
- swivel head seal
- minimum swivel head play and smooth rolling characteristic and increased service life due to the special dynamic Blickle riveting process
- steel truck lock with rubber pad
- height adjustment with swiveling operating and release lever

Wheel:

- PO series**
 - high-quality nylon 6, impact resistant, hardness 70 Shore D, colour natural white
- SPO series**
 - high-quality nylon 6, impact resistant, hardness 70 Shore D, extremely robust heavy-duty version, colour natural white
- ALTH series**
 - tread: high-quality polyurethane elastomer Blickle Extrathane®, hardness 92 Shore A, colour light brown
 - wheel centre: die-cast aluminium

Additional details:

- bracket series: page 99
- wheel series: page 69, 65
- bearing types: page 84–85

Swivel castors	Wheel Ø (D) [mm]	Wheel width [mm]	Load capacity [kg]	Bearing type	Total height (H) [mm]	Total height max. (h) [mm]	Stroke (T4) [mm]	Floor clearance foot max. (T3) [mm]	Plate size [mm]	Bolt hole spacing [mm]	Bolt hole Ø [mm]	Offset swivel castor [mm]
PO series												
HRLK-PO 82G-HN	80	37	230	plain bore	117	121	4	12	100 x 85	80 x 60	9	56
SPO series												
HRLK-SPO 80G-HN	80	37	250	plain bore	117	121	4	12	100 x 85	80 x 60	9	56
ALTH series												
HRLK-ALTH 80K-HN	80	30	180	ball bearing	117	121	4	12	100 x 85	80 x 60	9	56

Versions / options



	image ALTH series	electrically-conductive version, wheel non-marking grey	antistatic version, non-marking grey	with top plate 140x110/105x75–80 mm
Technical description page	65	50	50	107
Product code suffix		-EL	-AS	-3
Available for		PO, SPO series upon request	ALTH series upon request	upon request

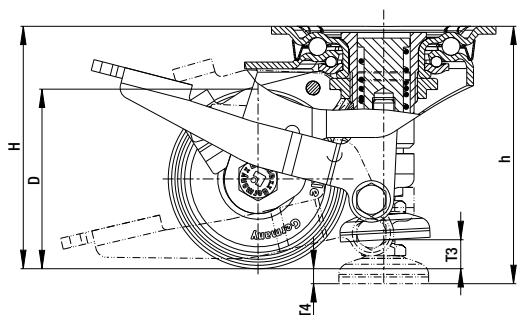

HRLK...-F series

Levelling castors with fixed lock and height-adjustable wheel, with top plate



150 kg

Bracket: HRLK...-F series

- strong pressed steel, zinc-plated, blue-passivated, Cr6-free
- double ball bearing in the swivel head
- swivel head seal
- minimum swivel head play and smooth rolling characteristic and increased service life due to the special dynamic Blickle riveting process
- steel truck lock with rubber pad
- height adjustment with swiveling operating lever

Wheel:

- PO series
- high-quality nylon 6, impact resistant, hardness 70 Shore D, colour natural white
- ALTH series
- tread: high-quality polyurethane elastomer Blickle Extrathane®, hardness 92 Shore A, colour light brown
- wheel centre: die-cast aluminium

Additional details:

- bracket series: page 100
- wheel series: page 69, 65
- bearing types: page 84–85

Swivel castors	Wheel Ø (D) [mm]	Wheel width [mm]	Load capacity [kg]	Bearing type	Total height (H) [mm]	Total height max. (h) [mm]	Stroke (T4) [mm]	Floor clearance foot max. (T3) [mm]	Plate size [mm]	Bolt hole spacing [mm]	Bolt hole Ø [mm]	Offset swivel castor [mm]
PO series												
HRLK-PO 80G-F	80	32	150	plain bore	117	122	2	5	100 x 85	80 x 60	9	52
ALTH series												
HRLK-ALTH 80K-F	80	30	150	ball bearing	117	122	2	5	100 x 85	80 x 60	9	52

Versions / options



	image ALTH series	electrically conductive version, wheel non-marking grey	antistatic version, non-marking grey	with top plate 140x110/105x75-80 mm
Technical description page	65	50	50	107
Product code suffix		-EL	-AS	-3
Available for		PO series upon request	ALTH series upon request	upon request

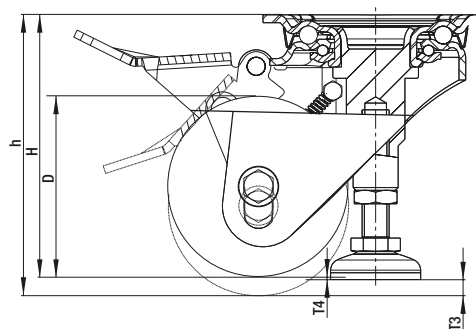

HRLK...-VS series

Height adjustment castors with adjustment screw, with top plate, with nylon wheel



230–280 kg

Bracket: HRLK...-VS series

- strong pressed steel, zinc-plated, blue-passivated, Cr6-free
- double ball bearing in the swivel head
- swivel head seal
- minimum swivel head play and smooth rolling characteristic and increased service life due to the special dynamic Blickle riveting process
- total height can be adjusted when stationary with adjustment screw (SW17), wheel locked in place with adjustment screw is used

Wheel: PO series

- high-quality nylon 6, impact resistant, hardness 70 Shore D, colour natural white

Additional details:

- bracket series: page 100
- wheel series: page 69
- bearing types: page 84–85

Swivel castors	Wheel Ø (D) [mm]	Wheel width [mm]	Load capacity [kg]	Bearing type	Total height (H) [mm]	Total height max. (h) [mm]	Displacement [mm]	Plate size [mm]	Bolt hole spacing [mm]	Bolt hole Ø [mm]	Offset swivel castor [mm]
HRLK-PO 82G-VS	80	37	230	plain bore	108	120	12	100 x 85	80 x 60	9	42
HRLK-PO 100G-VS	100	37	280	plain bore	128	140	12	100 x 85	80 x 60	9	45

Versions / options



	electrically conductive version, non-marking grey	directional lock (separate) 1 x 360°
Technical description page	50	115
Product code suffix	-ELS	RI-05.01
Available for	upon request	all

travelling operation

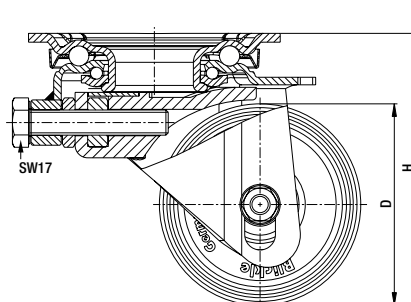

stationary operation

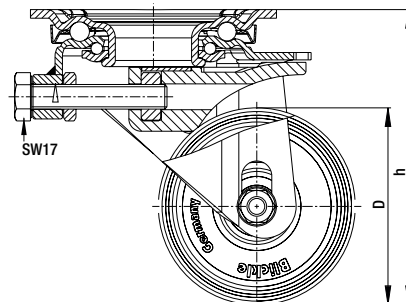

HRP-POA, HRSP-POA, HRSP-GSPO, HRIG-POA series

Levelling castors with integrated truck lock, with top plate or bolt hole female thread, with nylon or heavy-duty wheel made of cast nylon

180–2,000 kg

Bracket: HRP/HRSP series

- die-cast aluminium, powder-coated, colour ivory
- sealed ball bearing in the swivel head
- steel top plate
- truck lock made of hard rubber, series HRSP made of aluminium, black
- height adjustment using wrench or integrated adjustment wheel, series HRSP with wrench only
- steel parts zinc-plated, blue-passivated, Cr6-free

Wheel:

- POA series
 - high-quality nylon 6, impact resistant, hardness 70 Shore D, colour black
- GSPO series
 - high-quality cast nylon, reaction-injected, impact resistant, hardness 80 Shore D, colour natural beige

Additional details:

- bracket series: page 100
- wheel series: page 61–70
- bearing types: page 84–85



HRP



HRIG

Swivel castors	Wheel Ø (D) [mm]	Wheel width [mm]	Load capacity [kg]	Bearing type	Total height (H) [mm]	Total height max. (h) [mm]	Displacement (T4) [mm]	Plate size [mm]	Bolt hole spacing [mm]	Bolt hole Ø [mm]	Offset swivel castor [mm]
POA series											
HRP-POA 45G	45	18	180	plain bore	72	80	8	55 x 55	42 x 42	7	32
HRP-POA 50G	50	24	250	plain bore	84	90	6	73 x 73	58 x 58	7	38
HRP-POA 63G	63	30	500	plain bore	104	116	12	90 x 90	70 x 70	9	46
HRP-POA 72G	72	32	750	plain bore	122	134	12	95 x 95	70 x 70	11	52
HRSP-POA 72G	72	32	1,000	plain bore	122	134	12	95 x 95	70 x 70	11	55
GSPO series											
HRSP-GSPO 90G	90	55	2,000	plain bore	130	150	25	100 x 100	70 x 70	13	70

Load capacity determined under the following conditions:

- speed: max. 1 km/h
- temperature: +15 °C to +30 °C
- hardness, horizontal tread without obstacles
- route: A cooling off period of 15 minutes is required after a maximum of 50 m.

Versions / options



	image HRSP-GSPO series	stainless steel version	with bolt hole (female thread)
Technical description page			
Product code suffix			HRIG-POA ...
Available for		upon request	all wheel Ø in series HRP*

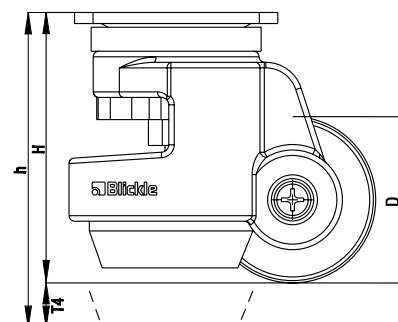

* Wheel Ø 45 mm: M8x12 mm; wheel Ø 50–63 mm: M12x15 mm; wheel Ø 72 mm: M16x16 mm; reduces the maximum total height of the HRIG-POA 63G and HRIG-POA 72G castors by 2 mm

HRLH-SPO, HRLHD-SPO series

**Levelling castors with integrated truck lock,
with top plate,
with heavy-duty nylon wheel**

300–600 kg

Bracket: HRLH/HRLHD series

- strong pressed steel, zinc-plated, blue-passivated, Cr6-free
- heavy fork and top plate
- double ball bearing in the swivel head
- bolted and secured central kingpin, extremely strong
- particularly resistant to shocks and impact due to **four specially-shaped, hardened bearing seats**
- steel truck lock with rubber pad
- height adjustment with wrench

Wheel: SPO series

- high-quality nylon 6, impact resistant, hardness 70 Shore D, extremely robust heavy-duty version, colour natural white

Additional details:

- bracket series: page 101
- wheel series: page 69
- bearing types: page 84–85



Swivel castors	Wheel Ø (D) [mm]	Wheel width [mm]	Load capacity [kg]	Bearing type	Total height (H) [mm]	Total height max. (h) [mm]	Displacement (T4) [mm]	Floor clearance foot max. (T3) [mm]	Plate size [mm]	Bolt hole spacing [mm]	Bolt hole Ø [mm]	Offset swivel castor [mm]
HRLH-SPO 75K	75	32	300	ball bearing	108	123	15	15	100 x 85	80 x 60	9	55
HRLHD-SPO 75K	75	2 x 32	600	ball bearing	108	123	15	15	100 x 85	80 x 60	9	55

Versions / options



	electrically conductive version, wheel non-marking grey	directional lock (separate) 1 x 360°
Technical description page	50	115
Product code suffix	-EL	RI-04.01
Available for	upon request	HRLH-SPO 75K

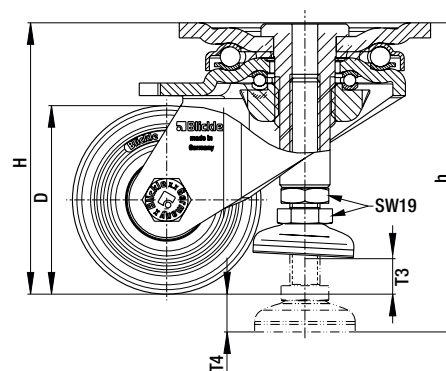

HRLSD series

Welded steel heavy-duty levelling castors with adjustable mounting height, with top plate

1,300 kg

Bracket: HRLSD series

- particularly robust welded steel construction, zinc-plated, yellow-passivated, Cr6-free
- axial grooved ball bearing ISO 104 and tapered roller bearing ISO 355 in the swivel head
- dust and splash-proof
- welded guide sleeve for extremely strong truck lock
- wheels and truck lock can be levelled using a wrench (SW24)
- grease nipple

Wheel:

- SPO series
- high-quality nylon 6, impact resistant, hardness 70 Shore D, extremely robust heavy-duty version, colour natural white
- GTH series
- tread: high-quality polyurethane elastomer Blickle Extrathane®, hardness 92 Shore A, colour light brown
 - wheel centre: rugged grey cast iron

Additional details:

- bracket series: page 101
- wheel series: page 66–69
- bearing types: page 84–85



Swivel castors	Wheel Ø (D) [mm]	Wheel width [mm]	Load capacity [kg]	Bearing type	Total height (H) [mm]	Total height max. (h) [mm]	Floor clearance foot max. [mm]	Plate size [mm]	Bolt hole spacing [mm]	Bolt hole Ø [mm]	Offset swivel castor [mm]
SPO series											
HRLSD-SPO 125K	125	2 x 40	1,300	ball bearing	170	210	40	175 x 140	140 x 105	14	70
GTH series											
HRLSD-GTH 127K	125	2 x 50	1,300	ball bearing	170	210	40	175 x 140	140 x 105	14	70

Floor clearance with screwed in truck lock and levelling screw

Versions / options



	image SPO series	electrically conductive version, wheel non-marking grey
Technical description page	69	50
Product code suffix		-EL
Available for		SPO series upon request

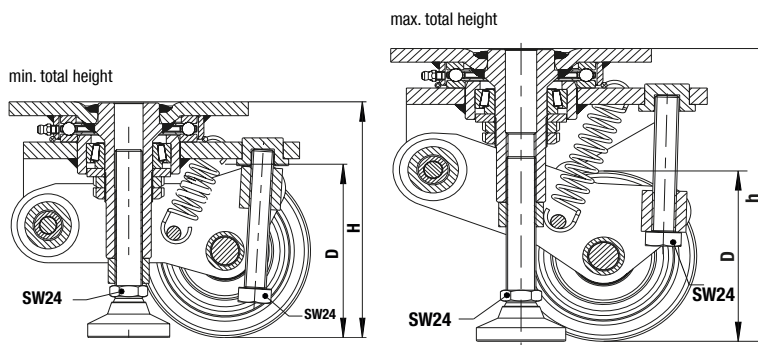

HRLK...-HYD series

Levelling castor set with hydraulic pump



750 kg (Set)

Bracket: HRLK...-HYD series

- strong pressed steel, zinc-plated, blue-passivated, Cr6-free
- double ball bearing in the swivel head
- swivel head seal
- minimum swivel head play and smooth rolling characteristic and increased service life due to the special dynamic Blickle riveting process
- steel truck lock with rubber pad

Wheel: PATH series

- tread: high-quality thermoplastic polyurethane (TPU), hardness 94 Shore A, colour dark grey, non-marking, non-staining
- wheel centre: high-quality nylon 6, impact resistant, colour silver grey

Additional details:

- bracket series: page 101
- wheel series: page 61
- bearing types: page 84–85

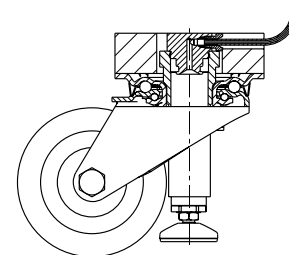

Swivel castors	Wheel Ø	Wheel width	Max. lifting force per levelling castor	Max. lifting force per system	Total height (H) [mm]	Total height max. (h) [mm]	Stroke (T4) [mm]	Floor clearance foot max. (T3) [mm]	Plate size [mm]	Bolt hole spacing [mm]	Bolt hole Ø [mm]	Offset swivel castor [mm]
	(D) [mm]	[mm]	[kg]	[kg]	[mm]	[mm]	[mm]	[mm]	[mm]	[mm]	[mm]	[mm]
SET HRLK-PATH 100KF-HYD-AK *	100	32	240	750	150	160	10	20	100 x 85	80 x 60	9	65
SET HRLK-PATH 100KF-HYD **	100	32	240	750	150	160	10	20	100 x 85	80 x 60	9	65

* With removable hand crank

** With folding hand crank

Set comprising:

- levelling castors (with synthetic adapter plate and pre-assembled hydraulic hose)
- hydraulic pump including hand crank
- assembly set with instructions





Application:

Levelling castors with an integrated hydraulic truck lock are an easy way to convert mobile equipment and transport units weighing up to 750 kg into stable worktops. The tried and tested hydraulic unit manufactured by the Swiss company Ergoswiss is used to raise four levelling castors in a centralised, synchronised and ergonomic fashion.

Description:

The hydraulic cylinders of each levelling castor are connected to a hydraulic pump attached to the centre of the unit using a hydraulic hose. Using the hand crank causes the hydraulic fluid to flow from the hydraulic pump into the hydraulic cylinders of the levelling castors. The raising motion of the truck locks lifts the levelling castors in a synchronised and silent manner. A wrench can be used to adjust the truck lock to compensate for uneven surfaces. The hand crank can be folded down or removed after use so that it is concealed behind the edge of the unit or table.

The hydraulic hoses (3m each), which come pre-assembled on the levelling castors, are cut to the desired length and connected to the hydraulic pump during installation.

Hydraulic pump:

Pump housing made from colourless anodised aluminium, four integrated hydraulic cylinders with four hose connections, foldable or removable hand crank, three holes (Ø 6.8 mm) for installing the pump.

- length of the hydraulic hoses: 3 m
- diameter of the hydraulic hoses: 4 mm
- hydraulic pump (LxWxH): 299 x 120 x 60 mm

Assembly set (incl.):

- 1 x double ring spanner with special opening
- 1 hose cutter
- 1 magnet
- 5 clamping rings
- 1 connecting screw (as replacement)
- instructions

Versions / options



heavy duty levelling castor set for total loads of up to 2,000 kg

Technical description page	
Product code suffix	SET HRLSD...-HYD
Available for	upon request

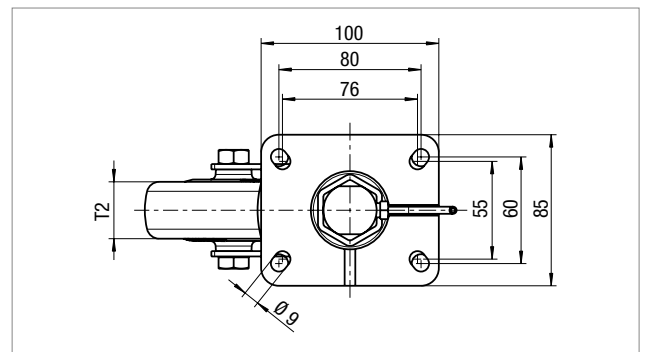
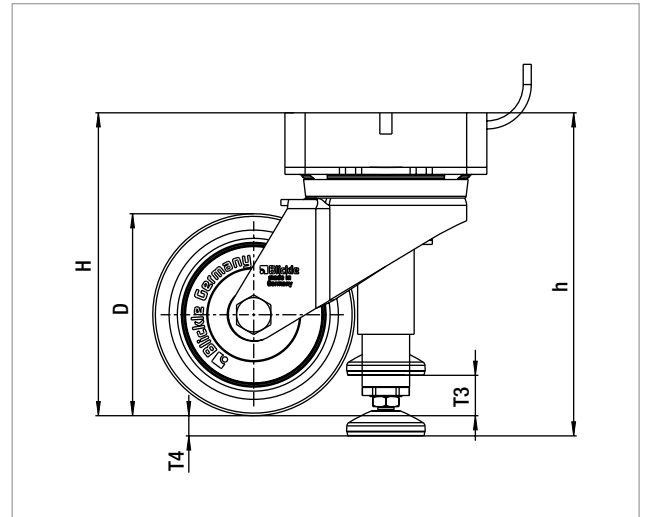

Hydraulic pump with folding hand crank

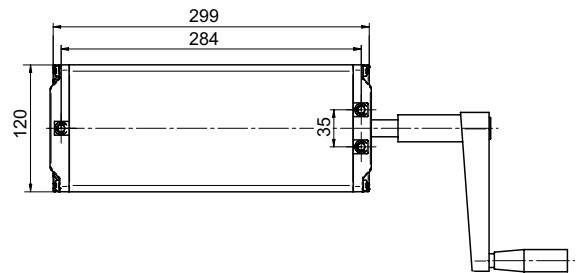

4 hose connections

