

Heat-resistant wheels and castors



Selection tool

Heat-resistant wheels and castors



Series	VEHI	VKHT	POSI	ALSI
Tread / tyre	Heat-resistant solid rubber		Highly heat-resistant silicone rubber	
Tread and tyre hardness	80 Shore A	85 Shore A	75 Shore A	75 Shore A
Non-marking	–	–	✓	✓
Wheel centre / rim	pressed steel	highly heat-resistant nylon	highly heat-resistant thermoplastic	aluminium
Wheel Ø	100–200 mm	100 mm	100–125 mm	100 mm
Load capacity up to	180 kg	100 kg	120 kg	100 kg
Temperature resistance	-25 to +200 °C	-30 to +260 °C temporarily up to +300 °C	-25 to +250 °C temporarily up to +300 °C	-25 to +250 °C temporarily up to +300 °C
Suitable for autoclaves	–	–	✓	–
Rolling resistance	■ ■ ■ ■ ■	■ ■ ■ ■ ■	■ ■ ■ ■ ■	■ ■ ■ ■ ■
Smooth operation and floor preservation	■ ■ ■ ■ ■	■ ■ ■ ■ ■	■ ■ ■ ■ ■	■ ■ ■ ■ ■
Wear resistance	■ ■ ■ ■ ■	■ ■ ■ ■ ■	■ ■ ■ ■ ■	■ ■ ■ ■ ■
For a description of the wheel, refer to	page 442	page 445	page 448	page 448
For information about swivel and fixed castors, refer to	page 443–444	page 446–447	page 449–452	page 449–450

■ ■ ■ ■ ■ excellent
 ■ ■ ■ ■ ■ very good
 ■ ■ ■ ■ ■ good
 ■ ■ ■ ■ ■ satisfactory
 ■ ■ ■ ■ ■ adequate
 ✓ yes
 – no



POH	POHI	PHN	G
Highly heat-resistant nylon	Highly heat-resistant thermoplastic	Phenolic resin	Grey cast iron
85 Shore D	85 Shore D	90 Shore D	180–220 HB
✓	✓	–	–
highly heat-resistant nylon	highly heat-resistant thermoplastic	phenolic resin	grey cast iron
80–200 mm	80–200 mm	80–200 mm	80–250 mm
720 kg	600 kg	500 kg	1,400 kg
-25 to +170 °C temporarily up to +200 °C	-25 to +250 °C temporarily up to +300 °C	-35 to +260 °C temporarily up to +300 °C	-100 to +600 °C
✓*	✓*	–	–
■ ■ ■ ■ ■	■ ■ ■ ■ ■	■ ■ ■ ■ ■	■ ■ ■ ■ ■
■ ■ ■ ■ ■	■ ■ ■ ■ ■	■ ■ ■ ■ ■	■ ■ ■ ■ ■
■ ■ ■ ■ ■	■ ■ ■ ■ ■	■ ■ ■ ■ ■	■ ■ ■ ■ ■
page 453	page 458	page 463	page 468
page 454–457	page 459–462	page 464–467	page 469–470

* Plain bore and version with stainless steel ball bearing with heat-resistant grease "HXK"

VEHI series

Heat-resistant wheels Blickle TempLine® Basic with solid rubber tyres, with pressed steel rim



65–180 kg

-25 °C to +200 °C

Tread and tyre hardness

80 Shore A

Smooth operation / floor preservation

very good

Rolling resistance

satisfactory

Wear resistance

sufficient

Tyre:

- highly heat-resistant solid rubber, hardness 80 Shore A
- very good operational comfort
- very good floor preservation, low-noise operation
- high tear resistance
- colour black

Rim:

- pressed steel
- zinc-plated, blue-passivated, Cr6-free

Other features:

- chemical resistance to many aggressive substances, except oils
- operating temperature: -25 °C to +200 °C
- majority of tyre flattening recovers when in motion under load

Additional details:

- wheel series: page 70
- tread: page 52
- bearing types: page 84–85
- chemical resistance: page 51

Wheels	Wheel Ø	Tyre width	Load capacity	Bearing type	Axle bore Ø	Hub length
	(D) [mm]	(T2) [mm]	[kg]		(d) [mm]	(T1) [mm]
VEHI 100/12R	100	30	65	roller bearing	12	45
VEHI 125/12R	125	37.5	90	roller bearing	12	45
VEHI 160/20R	160	40	120	roller bearing	20	60
VEHI 200/20R	200	50	180	roller bearing	20	60

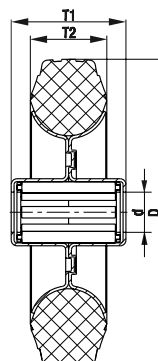

LI-VEHI, B-VEHI series

Heat-resistant pressed steel castors with top plate, with heat-resistant Blickle TempLine® Basic wheel with solid rubber tyres



65–180 kg

-25 °C to +200 °C

Bracket: LI/B series

- pressed steel, zinc-plated, blue-passivated, Cr6-free

Swivel bracket:

- double ball bearing in the swivel head
- strong central kingpin
- smooth rolling characteristic and low wear, increased service life
- swivel head play is set specifically for high-temperature applications
- highly heat-resistant grease

Wheel: VEHI series

- tyre: highly heat-resistant solid rubber, hardness 80 Shore A, colour black
- rim: pressed steel, zinc-plated, blue-passivated, Cr6-free

Additional details:

- bracket series: page 97
- brakes: page 112–113
- wheel series: page 442
- bearing types: page 84–85

Blickle TempLine® Basic

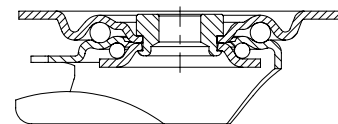

Swivel castors	Fixed castors	Swivel castors with "stop-fix" brake	Wheel Ø [mm]	Tyre width [mm]	Load capacity [kg]	Bearing type	Total height [mm]	Plate size [mm]	Bolt hole spacing [mm]	Bolt hole Ø [mm]	Offset swivel castor [mm]
LI-VEHI 100R	B-VEHI 100R	LI-VEHI 100R-FI	100	30	65	roller bearing	125	100 x 85	80 x 60	9	36
LI-VEHI 125R	B-VEHI 125R	LI-VEHI 125R-FI	125	37.5	90	roller bearing	150	100 x 85	80 x 60	9	38
LI-VEHI 160R	B-VEHI 160R	LI-VEHI 160R-FI	160	40	120	roller bearing	195	140 x 110	105 x 75–80	11	60
LI-VEHI 200R	B-VEHI 200R	LI-VEHI 200R-FI	200	50	180	roller bearing	235	140 x 110	105 x 75–80	11	65

LIR-VEHI series

Heat-resistant pressed steel castors with bolt hole, with heat-resistant Blickle TempLine® Basic wheel with solid rubber tyres



65–90 kg

-25 °C to +200 °C

Bracket: LIR series

- pressed steel, zinc-plated, blue-passivated, Cr6-free
- double ball bearing in the swivel head
- strong central kingpin
- smooth rolling characteristic and low wear, increased service life
- swivel head play is set specifically for high-temperature applications
- highly heat-resistant grease

Wheel: VEHI series

- tyre: highly heat-resistant solid rubber, hardness 80 Shore A, colour black
- rim: pressed steel, zinc-plated, blue-passivated, Cr6-free

Additional details:

- bracket series: page 97
- brakes: page 112–113
- wheel series: page 442
- bearing types: page 84–85

Blickle TempLine® Basic

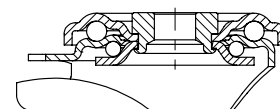

Swivel castors	Swivel castors with "stop-fix" brake	Wheel Ø [mm]	Tyre width [mm]	Load capacity [kg]	Bearing type	Total height [mm]	Plate Ø [mm]	Bolt hole Ø [mm]	Offset swivel castor [mm]
LIR-VEHI 100R	LIR-VEHI 100R-FI	100	30	65	roller bearing	125	70	13	36
LIR-VEHI 125R	LIR-VEHI 125R-FI	125	37.5	90	roller bearing	150	70	13	38

VKHT series

Heat-resistant Blickle TempLine® Special wheels with solid rubber tyres, with synthetic rim

100 kg

-30 °C to +260 °C

Tread and tyre hardness

85 Shore A

Smooth operation / floor preservation

good

Rolling resistance

satisfactory

Wear resistance

satisfactory



Tyre:

- highly heat-resistant solid rubber, hardness 85 Shore A
- high tear resistance
- colour black

Rim:

- highly heat-resistant nylon 6, impact resistant
- colour black

Other features:

- high chemical resistance to many aggressive substances, except oils
- operating temperature: -30 °C to +260 °C
- oven temperature temporarily up to +300 °C, wheel temperature must not exceed +260 °C
- tyre flattening recovers when in motion under load

Additional details:

- wheel series: page 71
- tread: page 52
- bearing types: page 84–85
- chemical resistance: page 51

Wheels	Wheel Ø	Tyre width	Load capacity	Bearing type	Axle bore Ø	Hub length
	(D) [mm]	(T2) [mm]	[kg]		(d) [mm]	(T1) [mm]
VKHT 100/12-38G	100	30	100	plain bore	12	38
VKHT 100/12-45G	100	30	100	plain bore	12	45

Versions / options



	PTFE coated stainless steel axle tube Ø 12/8x40 mm	PTFE coated stainless steel axle tube Ø 12/8x47 mm
Technical description page	117	117
Product code suffix	XAT 12x40	XAT 12x47
Available for	VKHT 100/12-38G	VKHT 100/12-45G

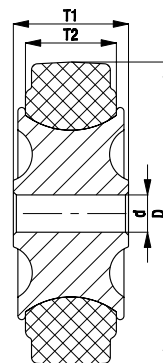

LI-VKHT series

Heat-resistant pressed steel castors with top plate, with heat-resistant Blickle TempLine® Special wheel with solid rubber tyres



100 kg

-30 °C to +260 °C

Bracket: LI series

- pressed steel, zinc-plated, blue-passivated, Cr6-free
- double ball bearing in the swivel head
- strong central kingpin
- smooth rolling characteristic and low wear, increased service life
- swivel head play is set specifically for high-temperature applications
- highly heat-resistant grease

Wheel: VKHT series

- tyre: highly heat-resistant solid rubber, hardness 85 Shore A, colour black
- rim: highly heat-resistant nylon 6, impact resistant, colour black

Additional details:

- bracket series: page 97
- brakes: page 112–113
- wheel series: page 445
- bearing types: page 84–85

Blickle TempLine® Special

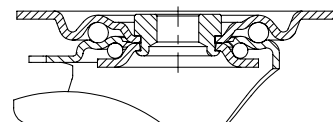

Swivel castors	Swivel castors with "stop-fix" brake	Wheel Ø [mm]	Tyre width [mm]	Load capacity [kg]	Bearing type	Total height [mm]	Plate size [mm]	Bolt hole spacing [mm]	Bolt hole Ø [mm]	Offset swivel castor [mm]
LI-VKHT 100G	LI-VKHT 100G-FI	100	30	100	plain bore	125	100 x 85	80 x 60	9	36

Versions / options



	with bolt hole, Ø 13 mm	with bolt hole, Ø 13 mm and "stop-fix" brake
Technical description page	97	112
Product code suffix	LIR-VKHT 100G	LIR-VKHT 100G-FI
Available for		

LIX-VKHT series

Heat-resistant stainless steel castors with top plate, with heat-resistant Blickle TempLine® Special wheel with solid rubber tyres



100 kg

-30 °C to +260 °C

Bracket: LIX series

- high-quality chromium-nickel steel (1.4301/AISI 304), stainless steel, vibration-ground finishing
- double ball bearing in the swivel head
- strong central kingpin
- smooth rolling characteristic and low wear, increased service life
- swivel head play is set specifically for high-temperature applications
- grease-free as standard ("-OF")
- PTFE coated stainless steel axle tube
- all parts including axle material are corrosion-resistant

Wheel: VKHT series

- tyre: highly heat-resistant solid rubber, hardness 85 Shore A, colour black
- rim: highly heat-resistant nylon 6, impact resistant, colour black

Additional details:

- bracket series: page 98
- brakes: page 112–113
- wheel series: page 445
- bearing types: page 84–85

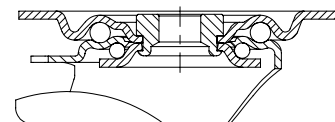

Swivel castors	Swivel castors with "stop-fix" brake	Wheel Ø [mm]	Tyre width [mm]	Load capacity [kg]	Bearing type	Total height [mm]	Plate size [mm]	Bolt hole spacing [mm]	Bolt hole Ø [mm]	Offset swivel castor [mm]
LIX-VKHT 100G-OF	LIX-VKHT 100G-FI-OF	100	30	100	plain bore	125	100 x 85	80 x 60	9	36

Versions / options



	with bolt hole, Ø 13 mm	with bolt hole, Ø 13 mm and "stop-fix" brake	with highly heat-resistant grease -30 °C to +250 °C
Technical description page	98	112	
Product code suffix	LIXR-VKHT 100G-OF	LIXR-VKHT 100G-FI-OF	remove -OF suffix
Available for			upon request

POSI, ALSI series

Heat-resistant Blickle TempLine®
Comfort wheels with silicone rubber tread,
with plastic or aluminium wheel centre

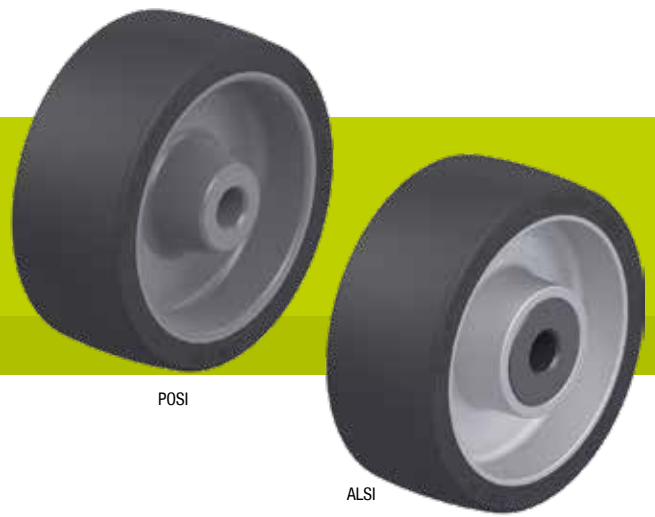

80–120 kg

-25 °C to +250 °C

Tread and tyre hardness	75 Shore A
Smooth operation / floor preservation	very good
Rolling resistance	good
Wear resistance	satisfactory



- Tread:**
- highly heat-resistant silicone rubber, hardness 75 Shore A
 - highly elastic
 - very good operational comfort
 - very good floor preservation, low-noise operation
 - ageing resistant
 - colour black, **non-marking**
 - vulcanised onto the wheel centre

- Wheel centre:**
- series POSI: highly heat-resistant thermoplastic, impact resistant, colour dark grey
 - series ALSI: die-cast aluminium

- Other features:**
- very high chemical resistance to many aggressive substances
 - operating temperature: -25 °C to +250 °C
 - oven temperature temporarily up to +300 °C, wheel temperature must not exceed +250 °C
 - POSI series: **suitable for autoclaves**

Wheels	Wheel Ø (D) [mm]	Wheel width (T2) [mm]	Load capacity [kg]	Bearing type	Axle bore Ø (d) [mm]	Hub length (T1) [mm]
POSI series						
POSI 101/12G	100	35	80	plain bore	12	38
POSI 100/12G	100	40	100	plain bore	12	45
POSI 125/12G	125	40	120	plain bore	12	45
ALSI series						
ALSI 100/12G	100	40	100	plain bore	12	45
ALSI 100/8HKA	100	40	100	ball bearing	8	46
ALSI 100/15HK	100	40	100	ball bearing	15	45

- Additional details:**
- wheel series: page 71
 - tread: page 53
 - bearing types: page 84–85
 - chemical resistance: page 51

Versions / options



	with non-marking grey tyre	PTFE coated stainless steel axle tube Ø 12/8x40 mm	PTFE coated stainless steel axle tube Ø 12/8x47 mm
Technical description page	52	117	117
Product code suffix	-SG	XAT 12x40	XAT 12x47
Available for	wheel Ø 125 mm*	POSI 101/12G	plain bore versions hub length 45 mm

* Operating temperature: up to +240 °C

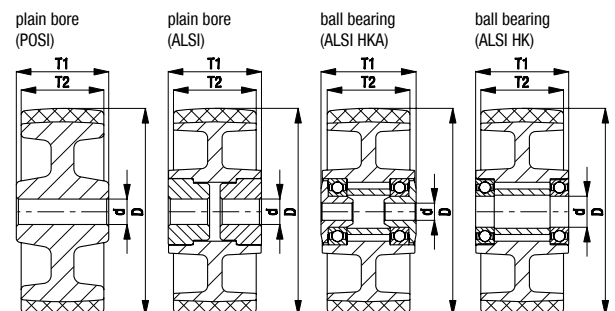

LI-POSI, B-POSI, LI-ALSI, B-ALSI series

Heat-resistant pressed steel castors with top plate, wheel with silicone rubber Blickle TempLine® Comfort tread



100–120 kg

-25 °C to +250 °C

Bracket: LI/B series

- pressed steel, zinc-plated, blue-passivated, Cr6-free

Swivel bracket:

- double ball bearing in the swivel head
- strong central kingpin
- smooth rolling characteristic and low wear, increased service life
- swivel head play is set specifically for high-temperature applications
- highly heat-resistant grease

Wheel: POSI, ALSI series

- tread: highly heat-resistant silicone rubber, hardness 75 Shore A, colour black, **non-marking**
- wheel centre:
 - POSI series: highly heat-resistant thermoplastic, impact resistant, colour dark grey
 - ALSI series: die-cast aluminium

Additional details:

- bracket series: page 97
- brakes: page 112–113
- wheel series: page 448
- bearing types: page 84–85

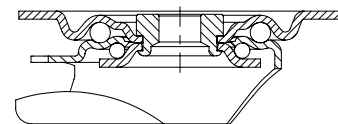

Swivel castors	Fixed castors	Swivel castors with "stop-fix" brake	Wheel Ø [mm]	Wheel width [mm]	Load capacity [kg]	Bearing type	Total height [mm]	Plate size [mm]	Bolt hole spacing [mm]	Bolt hole Ø [mm]	Offset swivel castor [mm]
LI-POSI series											
LI-POSI 100G	B-POSI 100G	LI-POSI 100G-FI	100	40	100	plain bore	125	100 x 85	80 x 60	9	36
LI-POSI 125G	B-POSI 125G	LI-POSI 125G-FI	125	40	120	plain bore	150	100 x 85	80 x 60	9	38
LI-ALSI series											
LI-ALSI 100G	B-ALSI 100G	LI-ALSI 100G-FI	100	40	100	plain bore	125	100 x 85	80 x 60	9	36
LI-ALSI 100HKA	B-ALSI 100HKA	LI-ALSI 100HKA-FI	100	40	100	ball bearing	125	100 x 85	80 x 60	9	36

Versions / options



	image LI-ALSI	with non-marking grey tyre	with PTFE coated stainless steel axle tube
Technical description page		52	117
Product code suffix		-SG	-XAT
Available for		wheel Ø 125 mm*	plain bore versions upon request

* Operating temperature: up to +240 °C

LIR-POSI, LIR-ALSI series

Heat-resistant pressed steel castors with bolt hole, wheel with silicone rubber Blickle TempLine® Comfort tread



Blickle TempLine® Comfort

100–120 kg

-25 °C to +250 °C

Bracket: LIR series

- pressed steel, zinc-plated, blue-passivated, Cr6-free
- double ball bearing in the swivel head
- strong central kingpin
- smooth rolling characteristic and low wear, increased service life
- swivel head play is set specifically for high-temperature applications
- highly heat-resistant grease

Wheel: POSI, ALSI series

- tread: highly heat-resistant silicone rubber, hardness 75 Shore A, colour black, **non-marking**
- wheel centre:
 - POSI series: highly heat-resistant thermoplastic, impact resistant, colour dark grey
 - ALSI series: die-cast aluminium

Additional details:

- bracket series: page 97
- brakes: page 112–113
- wheel series: page 448
- bearing types: page 84–85

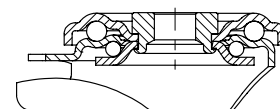

Swivel castors	Swivel castors with "stop-fix" brake	Wheel Ø [mm]	Wheel width [mm]	Load capacity [kg]	Bearing type	Total height [mm]	Plate Ø [mm]	Bolt hole Ø [mm]	Offset swivel castor [mm]
LIR-POSI series									
LIR-POSI 100G	LIR-POSI 100G-FI	100	40	100	plain bore	125	70	13	36
LIR-POSI 125G	LIR-POSI 125G-FI	125	40	120	plain bore	150	70	13	38
LIR-ALSI series									
LIR-ALSI 100G	LIR-ALSI 100G-FI	100	40	100	plain bore	125	70	13	36
LIR-ALSI 100HKA	LIR-ALSI 100HKA-FI	100	40	100	ball bearing	125	70	13	36

Versions / options



	image LIR-ALSI	with non-marking grey tyre	with PTFE coated stainless steel axle tube
Technical description page		52	117
Product code suffix		-SG	-XAT
Available for		wheel Ø 125 mm*	plain bore versions upon request

* Operating temperature: up to +240 °C

LIX-POSI, BX-POSI series

Heat-resistant stainless steel castors with top plate, wheel with silicone rubber Blickle TempLine® Comfort tread



100–120 kg

-25 °C to +250 °C

Bracket: LIX/BX series

- high-quality chromium-nickel steel (1.4301/AISI 304), stainless steel, vibration-ground finishing
- all parts including axle material are corrosion-resistant

Swivel bracket:

- double ball bearing in the swivel head
- strong central kingpin
- smooth rolling characteristic and low wear, increased service life
- swivel head play is set specifically for high-temperature applications
- grease-free as standard ("-OF")

Wheel: POSI series

- tread: highly heat-resistant silicone rubber, hardness 75 Shore A, colour black, **non-marking**
- wheel centre: highly heat-resistant thermoplastic, impact resistant, colour dark grey

suitable for autoclaves

Additional details:

- bracket series: page 98
- brakes: page 112–113
- wheel series: page 448
- bearing types: page 84–85

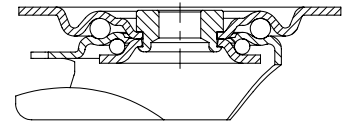

Swivel castors	Fixed castors	Swivel castors with "stop-fix" brake	Wheel Ø [mm]	Wheel width [mm]	Load capacity [kg]	Bearing type	Total height [mm]	Plate size [mm]	Bolt hole spacing [mm]	Bolt hole Ø [mm]	Offset swivel castor [mm]
LIX-POSI 100G-OF	BX-POSI 100G	LIX-POSI 100G-FI-OF	100	40	100	plain bore	125	100 x 85	80 x 60	9	36
LIX-POSI 125G-OF	BX-POSI 125G	LIX-POSI 125G-FI-OF	125	40	120	plain bore	150	100 x 85	80 x 60	9	38

Versions / options



	with non-marking grey tyre	with highly heat-resistant grease -30 °C to +250 °C	with PTFE coated stainless steel axle tube
Technical description page	52		117
Product code suffix	-SG	remove -OF suffix	-XAT
Available for	wheel Ø 125 mm*	swivel castors upon request	upon request

* Operating temperature: up to +240 °C

LIXR-POSI series

Heat-resistant stainless steel castors with bolt hole, wheel with silicone rubber
Blickle TempLine® Comfort tread



100–120 kg

-25 °C to +250 °C

Bracket: LIXR series

- high-quality chromium-nickel steel (1.4301/AISI 304), stainless steel, vibration-ground finishing
- double ball bearing in the swivel head
- strong central kingpin
- smooth rolling characteristic and low wear, increased service life
- swivel head play is set specifically for high-temperature applications
- grease-free as standard (*-OF*)
- all parts including axle material are corrosion-resistant

Wheel: POSI series

- tread: highly heat-resistant silicone rubber, hardness 75 Shore A, colour black, **non-marking**
- wheel centre: highly heat-resistant thermoplastic, impact resistant, colour dark grey

suitable for autoclaves

Additional details:

- bracket series: page 98
- brakes: page 112–113
- wheel series: page 448
- bearing types: page 84–85

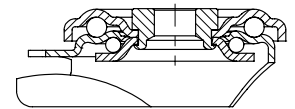

Swivel castors	Swivel castors with "stop-fix" brake	Wheel Ø [mm]	Wheel width [mm]	Load capacity [kg]	Bearing type	Total height [mm]	Plate Ø [mm]	Bolt hole Ø [mm]	Offset swivel castor [mm]
LIXR-POSI 100G-OF	LIXR-POSI 100G-FI-OF	100	40	100	plain bore	125	70	13	36
LIXR-POSI 125G-OF	LIXR-POSI 125G-FI-OF	125	40	120	plain bore	150	70	13	38

10

Versions / options



	with non-marking grey tyre	with highly heat-resistant grease -30 °C to +250 °C	with PTFE coated stainless steel axle tube
Technical description page	52		117
Product code suffix	-SG	remove -OF suffix	-XAT
Available for	wheel Ø 125 mm*	upon request	upon request

* Operating temperature: up to +240 °C

POH series

Heat-resistant

Blickle TempLine® PerformanceLight nylon wheels



215–720 kg

-25 °C to +170 °C

Tread and tyre hardness

85 Shore D

Smooth operation / floor preservation

satisfactory

Rolling resistance

excellent

Wear resistance

good

TempLine® PerformanceLight

Wheel:

- highly heat-resistant nylon, impact resistant, hardness 85 Shore D
- excellent rolling and swivel resistance
- easy operation on smooth surfaces
- high abrasion resistance
- colour natural
- suitable for autoclaves** (plain bore and version with stainless steel ball bearing with heat-resistant grease “-HXK”)

Other features:

- high chemical resistance to many aggressive substances
- operating temperature: -25 °C to +170 °C
- oven temperature temporarily up to +200 °C, wheel temperature must not exceed +170 °C

Additional details:

- wheel series: page 71
- tread: page 57
- bearing types: page 84–85
- chemical resistance: page 51

Wheels	Wheel Ø (D) [mm]	Wheel width (T2) [mm]	Load capacity up to +70 °C [kg]	Load capacity at +170 °C [kg]	Bearing type	Axle bore Ø (d) [mm]	Hub length (T1) [mm]
POH 81/12G	80	32	215	140	plain bore	12	35
POH 100/12-35G	100	30	240	160	plain bore	12	35
POH 100/12-45G	100	30	240	160	plain bore	12	45
POH 102/12G	100	38	300	200	plain bore	12	45
POH 102/15G	100	38	300	200	plain bore	15	45
POH 102/15HK	100	38	300	200	ball bearing	15	45
POH 125/12G	125	40	360	240	plain bore	12	45
POH 125/15G	125	40	360	240	plain bore	15	45
POH 125/15HK	125	40	420	280	ball bearing	15	45
POH 150/20G	150	50	600	400	plain bore	20	60
POH 150/20HK	150	50	600	400	ball bearing	20	50
POH 200/20G	200	50	720	480	plain bore	20	60
POH 200/20HK	200	50	720	480	ball bearing	20	50

Versions / options



	PTFE coated stainless steel axle tube Ø 12/8x37 mm	PTFE coated stainless steel axle tube Ø 12/8x47 mm	with stainless steel ball bearing with heat-resistant grease	with heavy-duty wheel centre for higher loads
Technical description page	117	117	84	
Product code suffix	XAT 12x37	XAT 12x47	-HXK	SPOH series
Available for	POH 81/12G POH 100/12-35G	POH 100/12-45G POH 102+125/12G	all ball bearing versions	upon request

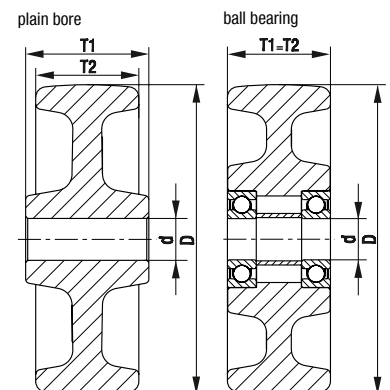

LI-POH, B-POH, LIK-POH, BK-POH series
**Heat-resistant pressed steel castors, top plate,
 with heat-resistant
 Blickle TempLine® PerformanceLight nylon wheel**

150–350 kg

-25 °C to +170 °C



Bracket: LI/B, LIK/BK series

- pressed steel, zinc-plated, blue-passivated, Cr6-free

Swivel bracket:

- double ball bearing in the swivel head
- strong central kingpin (series LIK without central kingpin, with heat-resistant swivel head seal)
- smooth rolling characteristic and low wear, increased service life
- swivel head play is set specifically for high-temperature applications
- highly heat-resistant grease

Wheel: POH series

- highly heat-resistant nylon, impact resistant, hardness 85 Shore D, colour natural

Additional details:

- bracket series: page 97–98
- brakes: page 112–113
- wheel series: page 453
- bearing types: page 84–85

TempLine® PerformanceLight

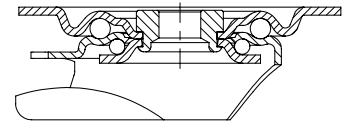

Swivel castors	Fixed castors	Swivel castors with "stop-fix" brake	Wheel Ø [mm]	Wheel width [mm]	Load capacity up to +70 °C [kg]	Bearing type	Total height [mm]	Plate size [mm]	Bolt hole spacing [mm]	Bolt hole Ø [mm]	Offset swivel castor [mm]
LI-POH 81G	B-POH 81G	LI-POH 81G-FI	80	32	150	plain bore	102	100 x 85	80 x 60	9	38
LI-POH 100G	B-POH 100G	LI-POH 100G-FI	100	30	150	plain bore	125	100 x 85	80 x 60	9	36
LIK-POH 102G-1	BK-POH 102G-1	LIK-POH 102G-1-FI	100	38	300	plain bore	130	100 x 85	80 x 60	9	45
LIK-POH 102HK-1	BK-POH 102HK-1	LIK-POH 102HK-1-FI	100	38	300	ball bearing	130	100 x 85	80 x 60	9	45
LI-POH 125G	B-POH 125G	LI-POH 125G-FI	125	40	150	plain bore	150	100 x 85	80 x 60	9	38
LIK-POH 125G-1	BK-POH 125G-1	LIK-POH 125G-1-FI	125	40	350	plain bore	155	100 x 85	80 x 60	9	48
LIK-POH 125HK-1	BK-POH 125HK-1	LIK-POH 125HK-1-FI	125	40	350	ball bearing	155	100 x 85	80 x 60	9	48
LI-POH 150G	B-POH 150G	LI-POH 150G-FI	150	50	350	plain bore	190	140 x 110	105 x 75–80	11	60
LI-POH 150HK	B-POH 150HK	LI-POH 150HK-FI	150	50	350	ball bearing	190	140 x 110	105 x 75–80	11	60
LI-POH 200G	B-POH 200G	LI-POH 200G-FI	200	50	350	plain bore	235	140 x 110	105 x 75–80	11	65
LI-POH 200HK	B-POH 200HK	LI-POH 200HK-FI	200	50	350	ball bearing	235	140 x 110	105 x 75–80	11	65

Load capacity may be reduced in temperatures over +70 °C, see page 453.

Versions / options



with PTFE coated stainless steel axle tube

Technical description page	117
Product code suffix	-XAT
Available for	Ø 80–125 mm plain bore versions upon request

LIR-POH series

Heat-resistant pressed steel castors, with bolt hole, with heat-resistant Blickle TempLine® PerformanceLight nylon wheel



150 kg

-25 °C to +170 °C

Bracket: LIR series

- pressed steel, zinc-plated, blue-passivated, Cr6-free
- double ball bearing in the swivel head
- strong central kingpin
- smooth rolling characteristic and low wear, increased service life
- swivel head play is set specifically for high-temperature applications
- highly heat-resistant grease

Wheel: POH series

- highly heat-resistant nylon, impact resistant, hardness 85 Shore D, colour natural

Additional details:

- bracket series: page 97
- brakes: page 112–113
- wheel series: page 453
- bearing types: page 84–85

TempLine® PerformanceLight

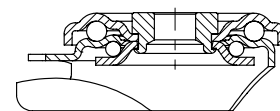

Swivel castors	Swivel castors with "stop-fix" brake	Wheel Ø [mm]	Wheel width [mm]	Load capacity up to +70 °C [kg]	Bearing type	Total height [mm]	Plate Ø [mm]	Bolt hole Ø [mm]	Offset swivel castor [mm]
LIR-POH 81G	LIR-POH 81G-FI	80	32	150	plain bore	102	70	13	38
LIR-POH 100G	LIR-POH 100G-FI	100	30	150	plain bore	125	70	13	36
LIR-POH 102G	LIR-POH 102G-FI	100	38	150	plain bore	125	70	13	36
LIR-POH 102HK	LIR-POH 102HK-FI	100	38	150	ball bearing	125	70	13	36
LIR-POH 125G	LIR-POH 125G-FI	125	40	150	plain bore	150	70	13	38
LIR-POH 125HK	LIR-POH 125HK-FI	125	40	150	ball bearing	150	70	13	38

Load capacity may be reduced in temperatures over +70 °C, see page 453.

Versions / options



with PTFE coated stainless steel axle tube

Technical description page	117
Product code suffix	-XAT
Available for	plain bore versions upon request

LIX-POH, BX-POH, LIKX-POH, BKX-POH series

Heat-resistant stainless steel castor, top plate, with heat-resistant Blickle TempLine® PerformanceLight nylon wheel



150–350 kg

-25 °C to +170 °C

Bracket: LIX/BX, LIKX/BKX series

- high-quality chromium-nickel steel (1.4301/AISI 304), stainless steel, vibration-ground finishing
- all parts including axle material are corrosion-resistant

Swivel bracket:

- double ball bearing in the swivel head
- strong central kingpin (series LIKX without central kingpin, with heat-resistant swivel head seal)
- smooth rolling characteristic and low wear, increased service life
- swivel head play is set specifically for high-temperature applications
- highly heat-resistant grease

Wheel: POH series

- highly heat-resistant nylon, impact resistant, hardness 85 Shore D, colour natural

suitable for autoclaves

Additional details:

- bracket series: page 98
- brakes: page 112–113
- wheel series: page 453
- bearing types: page 84–85

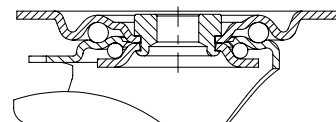

Swivel castors	Fixed castors	Swivel castors with "stop-fix" brake	Wheel Ø [mm]	Wheel width [mm]	Load capacity up to +70 °C [kg]	Bearing type	Total height [mm]	Plate size [mm]	Bolt hole spacing [mm]	Bolt hole Ø [mm]	Offset swivel castor [mm]
LIX-POH 81G	BX-POH 81G	LIX-POH 81G-FI	80	32	150	plain bore	102	100 x 85	80 x 60	9	38
LIX-POH 100G	BX-POH 100G	LIX-POH 100G-FI	100	30	150	plain bore	125	100 x 85	80 x 60	9	36
LIKX-POH 102G-1	BKX-POH 102G-1	LIKX-POH 102G-1-FI	100	38	300	plain bore	130	100 x 85	80 x 60	9	45
LIKX-POH 102HXK-1	BKX-POH 102HXK-1	LIKX-POH 102HXK-1-FI	100	38	300	ball bearing	130	100 x 85	80 x 60	9	45
LIX-POH 125G	BX-POH 125G	LIX-POH 125G-FI	125	40	150	plain bore	155	100 x 85	80 x 60	9	38
LIKX-POH 125G-1	BKX-POH 125G-1	LIKX-POH 125G-1-FI	125	40	300	plain bore	155	100 x 85	80 x 60	9	48
LIKX-POH 125HXK-1	BKX-POH 125HXK-1	LIKX-POH 125HXK-1-FI	125	40	300	ball bearing	155	100 x 85	80 x 60	9	48
LIX-POH 150G	BX-POH 150G	LIX-POH 150G-FI	150	50	350	plain bore	190	140 x 110	105 x 75–80	11	60
LIX-POH 150HXK	BX-POH 150HXK	LIX-POH 150HXK-FI	150	50	350	ball bearing	190	140 x 110	105 x 75–80	11	60
LIX-POH 200G	BX-POH 200G	LIX-POH 200G-FI	200	50	350	plain bore	235	140 x 110	105 x 75–80	11	65
LIX-POH 200HXK	BX-POH 200HXK	LIX-POH 200HXK-FI	200	50	350	ball bearing	235	140 x 110	105 x 75–80	11	65

Load capacity may be reduced in temperatures over +70 °C, see page 453.

Versions / options



grease-free swivel head, extremely smooth	with PTFE coated stainless steel axle tube
---	--

Technical description page	117	
Product code suffix	-OF	-XAT
Available for	series LIX wheel Ø 100 mm	Ø 80–125 mm plain bore versions upon request

LIXR-POH series

Heat-resistant stainless steel castors, with bolt hole, with heat-resistant Blickle TempLine® PerformanceLight nylon wheel



150 kg

-25 °C to +170 °C

Bracket: LIXR series

- high-quality chromium-nickel steel (1.4301/AISI 304), stainless steel, vibration-ground finishing
- double ball bearing in the swivel head
- strong central kingpin
- smooth rolling characteristic and low wear, increased service life
- swivel head play is set specifically for high-temperature applications
- highly heat-resistant grease
- all parts including axle material are corrosion-resistant

Wheel: POH series

- highly heat-resistant nylon, impact resistant, hardness 85 Shore D, colour natural

suitable for autoclaves

Additional details:

- bracket series: page 98
- brakes: page 112–113
- wheel series: page 453
- bearing types: page 84–85



Blickle TempLine® PerformanceLight

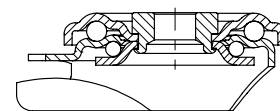

Swivel castors	Swivel castors with "stop-fix" brake	Wheel Ø [mm]	Wheel width [mm]	Load capacity up to +70 °C [kg]	Bearing type	Total height [mm]	Plate Ø [mm]	Bolt hole Ø [mm]	Offset swivel castor [mm]
LIXR-POH 81G	LIXR-POH 81G-FI	80	32	150	plain bore	102	70	13	38
LIXR-POH 100G	LIXR-POH 100G-FI	100	30	150	plain bore	125	70	13	36
LIXR-POH 102G	LIXR-POH 102G-FI	100	38	150	plain bore	125	70	13	36
LIXR-POH 102HXX	LIXR-POH 102HXX-FI	100	38	150	ball bearing	125	70	13	36
LIXR-POH 125G	LIXR-POH 125G-FI	125	40	150	plain bore	150	70	13	38
LIXR-POH 125HXX	LIXR-POH 125HXX-FI	125	40	150	ball bearing	150	70	13	38

Load capacity may be reduced in temperatures over +70 °C, see page 453.

Versions / options



grease-free swivel head, extremely smooth	with PTFE coated stainless steel axle tube
Technical description page	117
Product code suffix	-OF -XAT
Available for	wheel Ø 100 mm plain bore versions upon request

POHI series

Heat-resistant, thermoplastic

Blickle TempLine® Performance wheels



180–600 kg

-25 °C to +250 °C

Tread and tyre hardness

85 Shore D

Smooth operation / floor preservation

satisfactory

Rolling resistance

excellent

Wear resistance

satisfactory

Wheel:

- highly heat-resistant thermoplastic, impact resistant, hardness 85 Shore D
- excellent rolling and swivel resistance
- easy operation on smooth surfaces
- high abrasion resistance
- colour dark grey
- suitable for autoclaves** (plain bore and version with stainless steel ball bearing with heat-resistant grease “-HXK”)

Other features:

- high chemical resistance to many aggressive substances
- operating temperature: -25 °C to +250 °C
- oven temperature temporarily up to +300 °C, wheel temperature must not exceed +250 °C

Additional details:

- wheel series: page 72
- tread: page 57
- bearing types: page 84–85
- chemical resistance: page 51

Wheels	Wheel Ø (D) [mm]	Wheel width (T2) [mm]	Load capacity up to +70 °C [kg]	Load capacity at +170 °C [kg]	Load capacity at +250 °C [kg]	Bearing type	Axle bore Ø (d) [mm]	Hub length (T1) [mm]
POHI 81/12G	80	32	180	140	100	plain bore	12	35
POHI 100/12-35G	100	30	200	160	120	plain bore	12	35
POHI 100/12-45G	100	30	200	160	120	plain bore	12	45
POHI 102/12G	100	38	250	200	150	plain bore	12	45
POHI 102/15G	100	38	250	200	150	plain bore	15	45
POHI 102/15HK	100	38	250	200	150	ball bearing	15	40
POHI 125/12G	125	40	300	240	180	plain bore	12	45
POHI 125/15G	125	40	300	240	180	plain bore	15	45
POHI 125/15HK	125	40	350	280	210	ball bearing	15	40
POHI 150/20G	150	50	500	400	250	plain bore	20	60
POHI 150/20HK	150	50	500	400	250	ball bearing	20	50
POHI 200/20G	200	50	600	480	360	plain bore	20	60
POHI 200/20HK	200	50	600	480	360	ball bearing	20	50

Versions / options



	PTFE coated stainless steel axle tube Ø 12/8x37 mm	PTFE coated stainless steel axle tube Ø 12/8x47 mm	with stainless steel ball bearing with heat-resistant grease
Technical description page	117	117	84
Product code suffix	XAT 12x37	XAT 12x47	-HXK
Available for	POHI 81/12G POHI 100/12-35G	POHI 100/12-45G POHI 102+125/12G	ball bearing versions

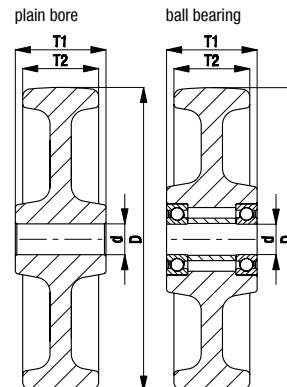

LI-POHI, B-POHI, LIK-POHI, BK-POHI series

Heat-resistant pressed steel castors, top plate, with heat-resistant

Blickle TempLine® Performance thermoplastic wheel



150–350 kg

-25 °C to +250 °C

Bracket: LI/B, LIK/BK series

- pressed steel, zinc-plated, blue-passivated, Cr6-free

Swivel bracket:

- double ball bearing in the swivel head (series LIK without central kingpin, with heat-resistant swivel head seal)
- smooth rolling characteristic and low wear, increased service life
- swivel head play is set specifically for high-temperature applications
- highly heat-resistant grease

Wheel: POHI series

- highly heat-resistant thermoplastic, impact resistant, hardness 85 Shore D, colour dark grey
- operating temperature: -25 °C to +250 °C

Additional details:

- bracket series: page 97–98
- brakes: page 112–113
- wheel series: page 458
- bearing types: page 84–85

Blickle TempLine® Performance

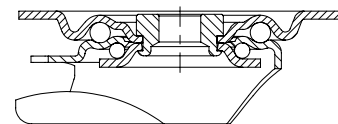

Swivel castors	Fixed castors	Swivel castors with "stop-fix" brake	Wheel Ø [mm]	Wheel width [mm]	Load capacity up to +70 °C [kg]	Bearing type	Total height [mm]	Plate size [mm]	Bolt hole spacing [mm]	Bolt hole Ø [mm]	Offset swivel castor [mm]
LI-POHI 81G	B-POHI 81G	LI-POHI 81G-FI	80	32	150	plain bore	102	100 x 85	80 x 60	9	38
LI-POHI 100G	B-POHI 100G	LI-POHI 100G-FI	100	30	150	plain bore	125	100 x 85	80 x 60	9	36
LIK-POHI 102G-1	BK-POHI 102G-1	LIK-POHI 102G-1-FI	100	38	250	plain bore	130	100 x 85	80 x 60	9	45
LIK-POHI 102HK-1	BK-POHI 102HK-1	LIK-POHI 102HK-1-FI	100	38	250	ball bearing	130	100 x 85	80 x 60	9	45
LI-POHI 125G	B-POHI 125G	LI-POHI 125G-FI	125	40	150	plain bore	150	100 x 85	80 x 60	9	38
LIK-POHI 125G-1	BK-POHI 125G-1	LIK-POHI 125G-1-FI	125	40	300	plain bore	155	100 x 85	80 x 60	9	48
LIK-POHI 125HK-1	BK-POHI 125HK-1	LIK-POHI 125HK-1-FI	125	40	350	ball bearing	155	100 x 85	80 x 60	9	48
LI-POHI 150G	B-POHI 150G	LI-POHI 150G-FI	150	50	350	plain bore	190	140 x 110	105 x 75–80	11	60
LI-POHI 150HK	B-POHI 150HK	LI-POHI 150HK-FI	150	50	350	ball bearing	190	140 x 110	105 x 75–80	11	60
LI-POHI 200G	B-POHI 200G	LI-POHI 200G-FI	200	50	350	plain bore	235	140 x 110	105 x 75–80	11	65
LI-POHI 200HK	B-POHI 200HK	LI-POHI 200HK-FI	200	50	350	ball bearing	235	140 x 110	105 x 75–80	11	65

Load capacity may be reduced in temperatures over +70 °C, see page 458.

10

Versions / options



with PTFE coated stainless steel axle tube

Technical description page

117

Product code suffix

-XAT

Available for

Ø 80–125 mm plain bore versions upon request

LIR-POHI series

Heat-resistant pressed steel castors with bolt hole, with heat-resistant Blickle TempLine® Performance thermoplastic wheel



150 kg

-25 °C to +250 °C

Bracket: LIR series

- pressed steel, zinc-plated, blue-passivated, Cr6-free
- double ball bearing in the swivel head
- strong central kingpin
- smooth rolling characteristic and low wear, increased service life
- swivel head play is set specifically for high-temperature applications
- highly heat-resistant grease

Wheel: POHI series

- highly heat-resistant thermoplastic, impact resistant, hardness 85 Shore D, colour dark grey
- operating temperature: -25 °C to +250 °C

Additional details:

- bracket series: page 97
- brakes: page 112–113
- wheel series: page 458
- bearing types: page 84–85

Blickle TempLine® Performance

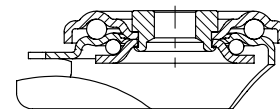

Swivel castors	Swivel castors with "stop-fix" brake	Wheel Ø [mm]	Wheel width [mm]	Load capacity up to +70 °C [kg]	Bearing type	Total height [mm]	Plate Ø [mm]	Bolt hole Ø [mm]	Offset swivel castor [mm]
LIR-POHI 81G	LIR-POHI 81G-FI	80	32	150	plain bore	102	70	13	38
LIR-POHI 100G	LIR-POHI 100G-FI	100	30	150	plain bore	125	70	13	36
LIR-POHI 102G	LIR-POHI 102G-FI	100	38	150	plain bore	125	70	13	36
LIR-POHI 102HK	LIR-POHI 102HK-FI	100	38	150	ball bearing	125	70	13	36
LIR-POHI 125G	LIR-POHI 125G-FI	125	40	150	plain bore	150	70	13	38
LIR-POHI 125HK	LIR-POHI 125HK-FI	125	40	150	ball bearing	150	70	13	38

Load capacity may be reduced in temperatures over +70 °C, see page 458.

Versions / options



with PTFE coated stainless steel axle tube

Technical description page	117
Product code suffix	-XAT
Available for	plain bore versions upon request

LIX-POHI, BX-POHI, LIKX-POHI, BKX-POHI series

Heat-resistant stainless steel castors, top plate, with heat-resistant Blickle TempLine® Performance thermoplastic wheel



150–350 kg

-25 °C to +250 °C

Bracket: LIX/BX, LIKX/BKX series

- high-quality chromium-nickel steel (1.4301/AISI 304), stainless steel, vibration-ground finishing
- all parts including axle material are corrosion-resistant

Swivel bracket:

- double ball bearing in the swivel head
- strong central kingpin (series LIXK without central kingpin, with heat-resistant swivel head seal)
- smooth rolling characteristic and low wear, increased service life
- swivel head play is set specifically for high-temperature applications
- highly heat-resistant grease

Wheel: POHI series

- highly heat-resistant thermoplastic, impact resistant, hardness 85 Shore D, colour dark grey
- operating temperature: -25 °C to +250 °C

suitable for autoclaves

Additional details:

- bracket series: page 98–99
- brakes: page 112–113
- wheel series: page 458
- bearing types: page 84–85

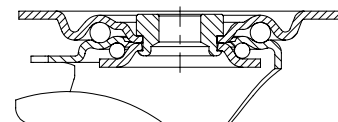

Swivel castors	Fixed castors	Swivel castors with "stop-fix" brake	Wheel Ø [mm]	Wheel width [mm]	Load capacity up to +70 °C [kg]	Bearing type	Total height [mm]	Plate size [mm]	Bolt hole spacing [mm]	Bolt hole Ø [mm]	Offset swivel castor [mm]
LIX-POHI 81G	BX-POHI 81G	LIX-POHI 81G-FI	80	32	150	plain bore	102	100 x 85	80 x 60	9	38
LIX-POHI 100G	BX-POHI 100G	LIX-POHI 100G-FI	100	30	150	plain bore	125	100 x 85	80 x 60	9	36
LIKX-POHI 102G-1	BKX-POHI 102G-1	LIKX-POHI 102G-1-FI	100	38	250	plain bore	130	100 x 85	80 x 60	9	45
LIKX-POHI 102HXK-1	BKX-POHI 102HXK-1	LIKX-POHI 102HXK-1-FI	100	38	250	ball bearing	130	100 x 85	80 x 60	9	45
LIX-POHI 125G	BX-POHI 125G	LIX-POHI 125G-FI	125	40	150	plain bore	150	100 x 85	80 x 60	9	38
LIKX-POHI 125G-1	BKX-POHI 125G-1	LIKX-POHI 125G-1-FI	125	40	300	plain bore	155	100 x 85	80 x 60	9	48
LIKX-POHI 125HXK-1	BKX-POHI 125HXK-1	LIKX-POHI 125HXK-1-FI	125	40	300	ball bearing	155	100 x 85	80 x 60	9	48
LIX-POHI 150G	BX-POHI 150G	LIX-POHI 150G-FI	150	50	350	plain bore	190	140 x 110	105 x 75–80	11	60
LIX-POHI 150HXK	BX-POHI 150HXK	LIX-POHI 150HXK-FI	150	50	350	ball bearing	190	140 x 110	105 x 75–80	11	60
LIX-POHI 200G	BX-POHI 200G	LIX-POHI 200G-FI	200	50	350	plain bore	235	140 x 110	105 x 75–80	11	65
LIX-POHI 200HXK	BX-POHI 200HXK	LIX-POHI 200HXK-FI	200	50	350	ball bearing	235	140 x 110	105 x 75–80	11	65

Load capacity may be reduced in temperatures over +70 °C, see page 458.

10

Versions / options



grease-free swivel head, extremely smooth	with PTFE coated stainless steel axle tube
Technical description page	117
Product code suffix	-OF -XAT
Available for	series LIX wheel Ø 100 mm Ø 80–125 mm plain bore versions upon request

LIXR-POHI series

Heat-resistant stainless steel castors with bolt hole, with heat-resistant Blickle TempLine® Performance thermoset wheel



150 kg

-25 °C to +250 °C

Bracket: LIXR series

- high-quality chromium-nickel steel (1.4301/AISI 304), stainless steel, vibration-ground finishing
- double ball bearing in the swivel head
- strong central kingpin
- smooth rolling characteristic and low wear, increased service life
- swivel head play is set specifically for high-temperature applications
- highly heat-resistant grease
- all parts including axle material are corrosion-resistant

Wheel: POHI series

- highly heat-resistant thermoplastic, impact resistant, hardness 85 Shore D, colour dark grey
- operating temperature: -25 °C to +250 °C

suitable for autoclaves

Additional details:

- bracket series: page 98
- brakes: page 112–113
- wheel series: page 458
- bearing types: page 84–85

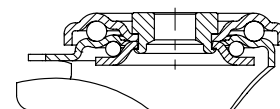

Swivel castors	Swivel castors with "stop-fix" brake	Wheel Ø [mm]	Wheel width [mm]	Load capacity up to +70 °C [kg]	Bearing type	Total height [mm]	Plate Ø [mm]	Bolt hole Ø [mm]	Offset swivel castor [mm]
LIXR-POHI 81G	LIXR-POHI 81G-FI	80	32	150	plain bore	102	70	13	38
LIXR-POHI 100G	LIXR-POHI 100G-FI	100	30	150	plain bore	125	70	13	36
LIXR-POHI 102G	LIXR-POHI 102G-FI	100	38	150	plain bore	125	70	13	36
LIXR-POHI 102HXK	LIXR-POHI 102HXK-FI	100	38	150	ball bearing	125	70	13	36
LIXR-POHI 125G	LIXR-POHI 125G-FI	125	40	150	plain bore	150	70	13	38
LIXR-POHI 125HXK	LIXR-POHI 125HXK-FI	125	40	150	ball bearing	150	70	13	38

Load capacity may be reduced in temperatures over +70 °C, see page 458.

Versions / options



grease-free swivel head, extremely smooth	with PTFE coated stainless steel axle tube
Technical description page	117
Product code suffix	-OF -XAT
Available for	wheel Ø 100 mm plain bore versions upon request

PHN series

Heat-resistant duroplast wheels Blickle TempLine® Classic



100–500 kg

-35 °C to +260 °C

Tread and tyre hardness
 90 Shore D

Smooth operation / floor preservation
 satisfactory

Rolling resistance
 excellent

Wear resistance
 sufficient



- Wheel:**
- phenolic resin, hardness 90 Shore D
 - very high static load capacity
 - easy operation on smooth surfaces
 - colour black

- Other features:**
- high chemical resistance to many aggressive substances
 - operating temperature:
 plain bore version: -35 °C to +260 °C,
 temporarily up to +300 °C
 ball bearing version: ("HK"): -25 °C to +250 °C
 ball bearing version: ("IK"): -30 °C to +260 °C
 - wheels are only conditionally suitable for uneven floors and crossing thresholds

- Additional details:**
- wheel series: page 72
 - tread: page 58
 - bearing types: page 84–85
 - chemical resistance: page 51

Wheels	Wheel Ø (D) [mm]	Wheel width (T2) [mm]	Load capacity [kg]	Bearing type	Axle bore Ø (d) [mm]	Hub length (T1) [mm]
PHN 81/12G	80	32	100	plain bore	12	35
PHN 80/12G	80	35	110	plain bore	12	40
PHN 100/12-35G	100	30	125	plain bore	12	35
PHN 100/12-45G	100	30	125	plain bore	12	45
PHN 102/12G	100	38	200	plain bore	12	45
PHN 102/15G	100	38	200	plain bore	15	45
PHN 102/15HK	100	38	200	ball bearing	15	40
PHN 102/15IK	100	38	200	ball bearing	15	40
PHN 125/12G	125	40	200	plain bore	12	45
PHN 125/15G	125	40	200	plain bore	15	45
PHN 125/15HK	125	40	200	ball bearing	15	40
PHN 125/15IK	125	40	200	ball bearing	15	40
PHN 150/20G	150	50	300	plain bore	20	60
PHN 150/20HK	150	50	300	ball bearing	20	50
PHN 150/20IK	150	50	300	ball bearing	20	50
PHN 200/20G *	200	50	500	plain bore	20	60

* Operating temperature from -30 °C to +230 °C

Versions / options



PTFE coated stainless steel axle tube Ø 12/8x37 mm	PTFE coated stainless steel axle tube Ø 12/8x47 mm
---	---

Technical description page	117	117
Product code suffix	XAT 12x37	XAT 12x47
Available for	PHN 81/12G PHN 100/12–35G	PHN 100/12–45G PHN 102+125/12G

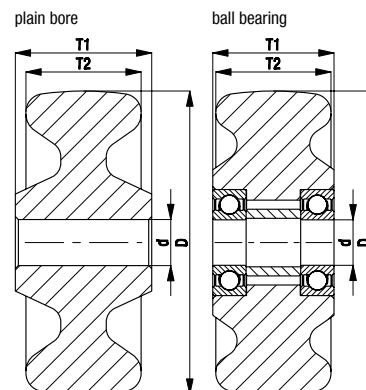

LI-PHN, B-PHN series

Heat-resistant pressed steel castors with top plate, with heat-resistant Blickle TempLine® Classic thermoset wheel



100–350 kg

-35 °C to +260 °C

Bracket: LI/B series

- pressed steel, zinc-plated, blue-passivated, Cr6-free

Swivel bracket:

- double ball bearing in the swivel head
- strong central kingpin
- smooth rolling characteristic and low wear, increased service life
- swivel head play is set specifically for high-temperature applications
- highly heat-resistant grease
- plain bore versions with PTFE coated stainless steel axle tube (wheel Ø 80–125 mm)

Wheel: PHN series

- phenolic resin, hardness 90 Shore D, colour black
- operating temperature:
 - plain bore version: -35 °C to +260 °C, temporarily up to +300 °C
 - ball bearing version: ("HK"): -25 °C to +250 °C
 - ball bearing version: ("IK"): -30 °C to +260 °C

Additional details:

- bracket series: page 97
- wheel series: page 463
- bearing types: page 84–85

Blickle TempLine® Classic

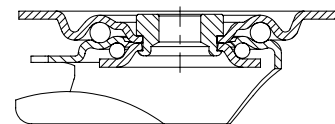

Swivel castors	Fixed castors	Wheel Ø [mm]	Wheel width [mm]	Load capacity [kg]	Bearing type	Total height [mm]	Plate size [mm]	Bolt hole spacing [mm]	Bolt hole Ø [mm]	Offset swivel castor [mm]
LI-PHN 81G	B-PHN 81G	80	32	100	plain bore	102	100 x 85	80 x 60	9	38
LI-PHN 100G	B-PHN 100G	100	30	125	plain bore	125	100 x 85	80 x 60	9	36
LI-PHN 102G	B-PHN 102G	100	38	150	plain bore	125	100 x 85	80 x 60	9	36
LI-PHN 102HK	B-PHN 102HK	100	38	150	ball bearing	125	100 x 85	80 x 60	9	36
LI-PHN 102IK	B-PHN 102IK	100	38	150	ball bearing	125	100 x 85	80 x 60	9	36
LI-PHN 125G	B-PHN 125G	125	40	150	plain bore	150	100 x 85	80 x 60	9	38
LI-PHN 125HK	B-PHN 125HK	125	40	150	ball bearing	150	100 x 85	80 x 60	9	38
LI-PHN 125IK	B-PHN 125IK	125	40	150	ball bearing	150	100 x 85	80 x 60	9	38
LI-PHN 150G	B-PHN 150G	150	50	300	plain bore	190	140 x 110	105 x 75–80	11	60
LI-PHN 150HK	B-PHN 150HK	150	50	300	ball bearing	190	140 x 110	105 x 75–80	11	60
LI-PHN 150IK	B-PHN 150IK	150	50	300	ball bearing	190	140 x 110	105 x 75–80	11	60
LI-PHN 200G *	B-PHN 200G *	200	50	350	plain bore	235	140 x 110	105 x 75–80	11	65

* Operating temperature from -30 °C to +230 °C

LIR-PHN series

Heat-resistant pressed steel castors with bolt hole, with heat-resistant Blickle TempLine® Classic thermoset wheel



Blickle TempLine® Classic

100–150 kg

-35 °C to +260 °C

Bracket: LIR series

- pressed steel, zinc-plated, blue-passivated, Cr6-free
- double ball bearing in the swivel head
- strong central kingpin
- smooth rolling characteristic and low wear, increased service life
- swivel head play is set specifically for high-temperature applications
- highly heat-resistant grease
- plain bore versions with PTFE coated stainless steel axle tube

Wheel: PHN series

- phenolic resin, hardness 90 Shore D, colour black
- operating temperature:
 - plain bore version: -35 °C to +260 °C, temporarily up to +300 °C
 - ball bearing version: ("HK"): -25 °C to +250 °C
 - ball bearing version: ("IK"): -30 °C to +260 °C

Additional details:

- bracket series: page 97
- wheel series: page 463
- bearing types: page 84–85

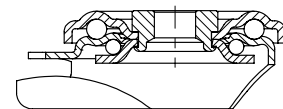

Swivel castors	Wheel Ø [mm]	Wheel width [mm]	Load capacity [kg]	Bearing type	Total height [mm]	Plate Ø [mm]	Bolt hole Ø [mm]	Offset swivel castor [mm]
LIR-PHN 81G	80	32	100	plain bore	102	70	13	38
LIR-PHN 100G	100	30	125	plain bore	125	70	13	36
LIR-PHN 102G	100	38	150	plain bore	125	70	13	36
LIR-PHN 102HK	100	38	150	ball bearing	125	70	13	36
LIR-PHN 102IK	100	38	150	ball bearing	125	70	13	36
LIR-PHN 125G	125	40	150	plain bore	150	70	13	38
LIR-PHN 125HK	125	40	150	ball bearing	150	70	13	38
LIR-PHN 125IK	125	40	150	ball bearing	150	70	13	38

LIX-PHN, BX-PHN series

Heat-resistant stainless steel castors with top plate, with heat-resistant Blickle TempLine® Classic thermoset wheel

100–350 kg

-35 °C to +260 °C

Bracket: LIX/BX series

- high-quality chromium-nickel steel (1.4301/AISI 304), stainless steel, vibration-ground finishing
- all parts including axle material are corrosion-resistant

Swivel bracket:

- double ball bearing in the swivel head
- smooth rolling characteristic and low wear, increased service life
- swivel head play is set specifically for high-temperature applications
- highly heat-resistant grease
- PTFE coated stainless steel axle tube (wheel Ø 80–125 mm)

Wheel: PHN series

- phenolic resin, hardness 90 Shore D, colour black
- Operating temperature from -35 °C to +260 °C, temporarily up to +300 °C

Additional details:

- bracket series: page 98
- wheel series: page 463
- bearing types: page 84–85

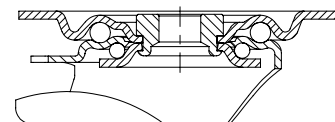

Swivel castors	Fixed castors	Wheel Ø [mm]	Wheel width [mm]	Load capacity [kg]	Bearing type	Total height [mm]	Plate size [mm]	Bolt hole spacing [mm]	Bolt hole Ø [mm]	Offset swivel castor [mm]
LIX-PHN 81G	BX-PHN 81G	80	32	100	plain bore	102	100 x 85	80 x 60	9	38
LIX-PHN 100G	BX-PHN 100G	100	30	125	plain bore	125	100 x 85	80 x 60	9	36
LIX-PHN 102G	BX-PHN 102G	100	38	150	plain bore	125	100 x 85	80 x 60	9	36
LIX-PHN 125G	BX-PHN 125G	125	40	150	plain bore	150	100 x 85	80 x 60	9	38
LIX-PHN 150G	BX-PHN 150G	150	50	300	plain bore	190	140 x 110	105 x 75–80	11	60
LIX-PHN 200G *	BX-PHN 200G *	200	50	350	plain bore	235	140 x 110	105 x 75–80	11	65

* Operating temperature from -30 °C to +230 °C

Versions / options



grease-free swivel head, extremely smooth

Technical description page

Product code suffix

-OF

Available for

wheel Ø 100 mm

LIXR-PHN series

Heat-resistant stainless steel castors with bolt hole, with heat-resistant Blickle TempLine® Classic thermoset wheel



100–150 kg

-35 °C to +260 °C

Bracket: LIXR series

- high-quality chromium-nickel steel (1.4301/AISI 304), stainless steel, vibration-ground finishing
- double ball bearing in the swivel head
- strong central kingpin
- smooth rolling characteristic and low wear, increased service life
- swivel head play is set specifically for high-temperature applications
- highly heat-resistant grease
- PTFE coated stainless steel axle tube
- all parts including axle material are corrosion-resistant

Wheel: PHN series

- phenolic resin, hardness 90 Shore D, colour black
- Operating temperature from -35 °C to +260 °C, temporarily up to +300 °C

Additional details:

- bracket series: page 98
- wheel series: page 463
- bearing types: page 84–85

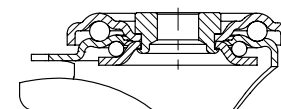

Swivel castors	Wheel Ø [mm]	Wheel width [mm]	Load capacity [kg]	Bearing type	Total height [mm]	Plate Ø [mm]	Bolt hole Ø [mm]	Offset swivel castor [mm]
LIXR-PHN 81G	80	32	100	plain bore	102	70	13	38
LIXR-PHN 100G	100	30	125	plain bore	125	70	13	36
LIXR-PHN 102G	100	38	150	plain bore	125	70	13	36
LIXR-PHN 125G	125	40	150	plain bore	150	70	13	38

Versions / options



grease-free swivel head, extremely smooth

Technical description page

Product code suffix

-OF

Available for

wheel Ø 100 mm

G series Cast iron wheels

250–1,400 kg

-100 °C to +600 °C

Tread and tyre hardness

180–220 HB

Smooth operation / floor preservation

sufficient

Rolling resistance

excellent

Wear resistance

excellent



Wheel:

- rugged grey cast iron, hardness 180–220 HB
- with grease nipple
- extremely low rolling and swivel resistance
- outstanding wear resistance
- machined tread and edges
- lacquered, colour silver

Other features:

- chemical resistance to many aggressive substances
- operating temperature:
plain bore version: -100 °C to +600 °C
ball bearing version: -30 °C to +300 °C
- consider the surface pressure on sensitive floors due to high point loads
- provide adequate lubrication on a regular basis for plain bore version
- to be lubricated according to the application temperature

Additional details:

- wheel series: page 70
- tread: page 59
- bearing types: page 84–85
- chemical resistance: page 51

Wheels	Wheel Ø	Wheel width	Load capacity up to +70 °C	Load capacity at +300 °C	Bearing type	Axle bore Ø	Hub length
	(D) [mm]	(T2) [mm]	[kg]	[kg]		(d) [mm]	(T1) [mm]
G 80/12G	80	25	250	200	plain bore	12	35
G 80/15G	80	25	250	200	plain bore	15	35
G 100/15G	100	35	400	320	plain bore	15	45
G 100/15IK	100	35	400	320	ball bearing	15	40
G 125/15G	125	35	450	360	plain bore	15	45
G 125/15IK	125	35	450	360	ball bearing	15	45
G 127/20G	125	50	750	600	plain bore	20	60
G 127/20IK	125	50	750	370	ball bearing	20	60
G 150/20G	150	50	900	720	plain bore	20	60
G 150/20IK	150	50	900	450	ball bearing	20	60
G 200/20G	200	50	1,100	880	plain bore	20	60
G 200/20IK	200	50	1,100	500	ball bearing	20	60
G 250/25G	250	60	1,400	1,100	plain bore	25	65
G 250/25IK	250	60	1,300	650	ball bearing	25	70

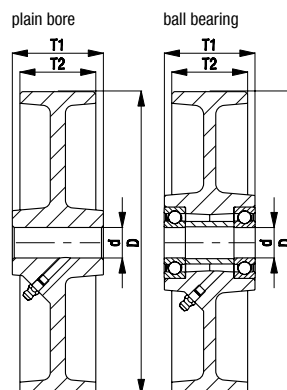

LI-G, BI-G, LIK-G, BIK-G series

Heat-resistant pressed steel castors with top plate, with cast iron wheel



150–350 kg

-30 °C to +270 °C

Bracket: LI/BI, LIK/BIK series

- pressed steel, zinc-plated, blue-passivated, Cr6-free

Swivel bracket:

- double ball bearing in the swivel head
- strong central kingpin (series LIK without central kingpin, with heat-resistant swivel head seal)
- smooth rolling characteristic and low wear, increased service life
- swivel head play is set specifically for high-temperature applications
- highly heat-resistant grease

Wheel: G series

- rugged grey cast iron, hardness 180–220 HB, grease nipple, lacquered, colour silver

Additional details:

- bracket series: page 97–98
- brakes: page 112–113
- wheel series: page 468
- bearing types: page 84–85

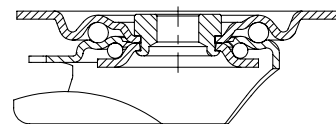

Swivel castors	Fixed castors	Swivel castors with "stop-fix" brake	Wheel Ø [mm]	Wheel width [mm]	Load capacity up to +70 °C [kg]	Bearing type	Total height [mm]	Plate size [mm]	Bolt hole spacing [mm]	Bolt hole Ø [mm]	Offset swivel castor [mm]
LI-G 80G	BI-G 80G	LI-G 80G-FI	80	25	150	plain bore	102	100 x 85	80 x 60	9	38
LI-G 100G	BI-G 100G	LI-G 100G-FI	100	35	150	plain bore	125	100 x 85	80 x 60	9	36
LIK-G 100G-1	BIK-G 100G-1	LIK-G 100G-1-FI	100	35	350	plain bore	130	100 x 85	80 x 60	9	45
LI-G 100IK	BI-G 100IK	LI-G 100IK-FI	100	35	150	ball bearing	125	100 x 85	80 x 60	9	36
LIK-G 100IK-1	BIK-G 100IK-1	LIK-G 100IK-1-FI	100	35	350	ball bearing	130	100 x 85	80 x 60	9	45
LI-G 125G	BI-G 125G	LI-G 125G-FI	125	35	150	plain bore	150	100 x 85	80 x 60	9	38
LIK-G 125G-1	BIK-G 125G-1	LIK-G 125G-1-FI	125	35	350	plain bore	155	100 x 85	80 x 60	9	48
LI-G 125IK	BI-G 125IK	LI-G 125IK-FI	125	35	150	ball bearing	150	100 x 85	80 x 60	9	38
LIK-G 125IK-1	BIK-G 125IK-1	LIK-G 125IK-1-FI	125	35	350	ball bearing	155	100 x 85	80 x 60	9	48
LI-G 150G	BI-G 150G	LI-G 150G-FI	150	50	350	plain bore	190	140 x 110	105 x 75–80	11	60
LI-G 150IK	BI-G 150IK	LI-G 150IK-FI	150	50	350	ball bearing	190	140 x 110	105 x 75–80	11	60
LI-G 200G	BI-G 200G	LI-G 200G-FI	200	50	350	plain bore	235	140 x 110	105 x 75–80	11	65
LI-G 200IK	BI-G 200IK	LI-G 200IK-FI	200	50	350	ball bearing	235	140 x 110	105 x 75–80	11	65

Load capacity may be reduced in temperatures over +70 °C, see page 468.

LIO-G, BO-G series

Heat-resistant welded steel heavy-duty castors, with top plate, with cast iron wheel



750–1,250 kg

-30 °C to +270 °C

Bracket: LIO/BO series

- solid welded steel construction
- Swivel bracket:
 - double ball bearing in the swivel head
 - particularly resistant to shocks and impact due to **four specially-shaped, hardened bearing seats**
 - bolted and secured welded central kingpin, extremely strong
 - swivel head seal with labyrinth design
 - grease nipple
 - highly heat-resistant grease

Wheel: G series

- rugged grey cast iron, hardness 180–220 HB, grease nipple, lacquered, colour silver

Additional details:

- bracket series: page 98
- brakes: page 112–113
- wheel series: page 468
- bearing types: page 84–85

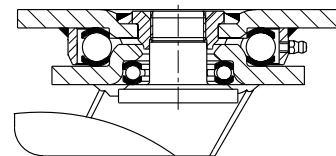

Swivel castors	Fixed castors	Swivel castor with "stop-top" brake	Wheel Ø [mm]	Wheel width [mm]	Load capacity up to +70 °C [kg]	Bearing type	Total height [mm]	Plate size [mm]	Bolt hole spacing [mm]	Bolt hole Ø [mm]	Offset swivel castor [mm]
LIO-G 127IK	BO-G 127IK	LIO-G 127IK-ST	125	50	750	ball bearing	170	140 x 110	105 x 75–80	11	50
LIO-G 150IK	BO-G 150IK	LIO-G 150IK-ST	150	50	900	ball bearing	200	140 x 110	105 x 75–80	11	55
LIO-G 200IK	BO-G 200IK	LIO-G 200IK-ST	200	50	1,000	ball bearing	245	140 x 110	105 x 75–80	11	60
LIO-G 250IK	BO-G 250IK	LIO-G 250IK-ST	250	60	1,250	ball bearing	295	140 x 110	105 x 75–80	11	70

At a temperature of +270 °C, the load capacity is reduced by 40%.

Versions / options



with directional lock 4 x 90°

Technical description page

115

Product code suffix

-RI4

Available for

wheel Ø 125–200 mm