

## Antistatic and electrically conductive wheels



9

## Selection tool

### Antistatic and electrically conductive wheels



Series	TPA...-ELS	VPA...-EL	VE...- / V...-EL	ALEV...-EL	ALEV...-SG-AS	PATH...-ELS
Tread / tyre	Thermoplastic rubber-elastomer	Standard solid rubber		Elastic solid rubber, smooth rolling quality, "Blickle Easy Roll"		Thermoplastic polyurethane
Tread and tyre hardness	85 Shore A	80 Shore A	80 Shore A	65 Shore A	65 Shore A	94 Shore A
Non-marking	✓	–	–	–	✓	✓
Wheel centre / rim	polypropylene	polypropylene	pressed steel	aluminium	aluminium	nylon
Wheel Ø	50–200 mm	50–150 mm	80–250 mm	100–250 mm	100–250 mm	50–200 mm
Load capacity up to	160 kg	100 kg	295 kg	650 kg	550 kg	325 kg
Rolling resistance	■■■■■	■■■■	■■■■	■■■■■	■■■■■	■■■■■
Smooth operation and floor preservation	■■■■■	■■■■■	■■■■■	■■■■■	■■■■■	■■■■■
Speeds up to	4 km/h	4 km/h	4 km/h	10 km/h	10 km/h	4 km/h
Electrical conductivity (ohmic resistance)	≤ 10 <sup>4</sup> Ω	≤ 10 <sup>4</sup> Ω	≤ 10 <sup>4</sup> Ω	≤ 10 <sup>4</sup> Ω	≤ 10 <sup>7</sup> Ω	≤ 10 <sup>4</sup> Ω
For a description of the wheel, refer to	page 426	page 427	page 428	page 429	page 430	page 431
For information about swivel and fixed castors, refer to	page 123–126, 187–188, 390–391, 399–400	page 128–132	page 196–198 / 201	page 222–227	page 222–227	page 137–140, 259–262, 394–395, 407–408

■■■■■ excellent   
 ■■■■ very good   
 ■■■■ good   
 ■■■ satisfactory   
 ■ adequate   
 ✓ yes    – no



ALTH...-AS	ALST...-AS	PP...-EL	PO...-ELS	G	SVS
Polyurethane-elastomer Blickle Extrathane®	Polyurethane-elastomer Blickle Softhane®	Polypropylene	Nylon	Grey cast iron	Heat-treatable steel
92 Shore A	75 Shore A	60 Shore D	70 Shore D	180–220 HB	190–230 HB
✓	✓	–	✓	–	✓
aluminium	aluminium	polypropylene	nylon	grey cast iron	heat-treatable steel
80–250 mm	100–200 mm	100–200 mm	80–200 mm	80–250 mm	65–300 mm
1,250 kg	750 kg	450 kg	600 kg	1,400 kg	15,000 kg
■ ■ ■ ■ ■ □	■ ■ ■ ■ ■ □	■ ■ ■ ■ ■ □	■ ■ ■ ■ ■ ■	■ ■ ■ ■ ■ ■	■ ■ ■ ■ ■ ■
■ ■ ■ ■ ■ □	■ ■ ■ ■ ■ □	■ ■ ■ ■ ■ □	■ ■ ■ ■ ■ □	■ ■ ■ ■ ■ □	■ ■ ■ ■ ■ □
10 km/h	10 km/h	4 km/h	4 km/h	4 km/h	4 km/h
≤ 10 <sup>7</sup> Ω	≤ 10 <sup>7</sup> Ω	≤ 10 <sup>4</sup> Ω	≤ 10 <sup>4</sup> Ω	≤ 10 <sup>4</sup> Ω	≤ 10 <sup>4</sup> Ω
page 432	page 433	page 434	page 435	page 436	page 437
page 275–281	page 295–300	page 337–339	page 345–354, 417–420	page 377–381, 469–470	page 383–384

## TPA...-ELS series

**Wheels with thermoplastic rubber tread,  
with polypropylene wheel centre  
electrically conductive, non-marking**



30–160 kg

**Tread and tyre hardness**

85 Shore A

**Smooth operation / floor preservation**

good

**Rolling resistance**

very good

**Wear resistance**

satisfactory

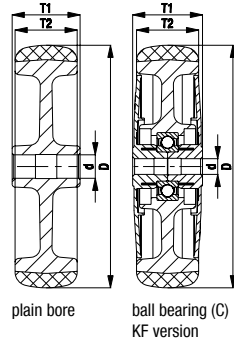

**Tread:**

- high-quality thermoplastic rubber-elastomer (TPE), hardness 85 Shore A
- low rolling and swivel resistance
- colour grey, non-marking
- chemically-bonded inseparable connection with the wheel centre

**Wheel centre:**

- high-quality polypropylene, impact resistant
- colour black

**Other features:**

- KF version: with synthetic thread guard, large
- KFD version: with synthetic thread guard, large, with additional ball bearing seal
- very high chemical resistance to many aggressive substances
- operating temperature: -20 °C to +60 °C, reduced load capacity over +30 °C
- tread contains oil, may stain sensitive surfaces. alternatives: Series VPA, PATH
- electrical conductivity (ohmic resistance)  $\leq 10^4 \Omega$

**Additional details:**

- wheel series: page 60
- tread: page 52
- bearing types: page 84–85
- chemical resistance: page 51

Wheels	Wheel Ø (D) [mm]	Wheel width (T2) [mm]	Load capacity [kg]	Bearing type	Axle bore Ø (d) [mm]	Hub length (T1) [mm]
TPA 50/8G-ELS	50	19	30	plain bore	8	22
TPA 50/6KF-ELS	50	19	30	ball bearing (C)	6	23
TPA 50/6KFD-ELS	50	19	30	ball bearing (C)	6	23
TPA 75/8G-ELS	75	25	50	plain bore	8	29.5
TPA 75/6KF-ELS	75	25	50	ball bearing (C)	6	31
TPA 75/6KFD-ELS	75	25	50	ball bearing (C)	6	31
TPA 80/12G-ELS	80	32	65	plain bore	12	35
TPA 80/8KF-ELS	80	32	65	ball bearing (C)	8	36
TPA 80/8KFD-ELS	80	32	65	ball bearing (C)	8	36
TPA 100/8G-ELS	100	25	60	plain bore	8	29.5
TPA 101/12G-ELS	100	32	70	plain bore	12	35
TPA 102/12G-ELS	100	32	70	plain bore	12	45
TPA 101/8KF-ELS	100	32	70	ball bearing (C)	8	36
TPA 101/8KFD-ELS	100	32	70	ball bearing (C)	8	36
TPA 102/8KF-ELS	100	32	70	ball bearing (C)	8	46
TPA 102/8KFD-ELS	100	32	70	ball bearing (C)	8	46
TPA 126/12G-ELS	125	32	80	plain bore	12	35
TPA 127/12G-ELS	125	32	80	plain bore	12	45
TPA 126/8KF-ELS	125	32	80	ball bearing (C)	8	36
TPA 126/8KFD-ELS	125	32	80	ball bearing (C)	8	36
TPA 127/8KF-ELS	125	32	80	ball bearing (C)	8	46
TPA 127/8KFD-ELS	125	32	80	ball bearing (C)	8	46
TPA 160/20G-ELS	160	40	130	plain bore	20	60
TPA 200/20G-ELS	200	40	160	plain bore	20	60

## Castor series



	LPA-TPA / LKPA-TPA	LDA-TPA	LE-TPA	LPXA-TPA / LKPXA-TPA	LEX-TPA
Page	124	126	187	391	399
Load capacity class					
Available for	wheel Ø 50–125 mm*	wheel Ø 50–75 mm*	wheel Ø 80–200 mm*	wheel Ø 50–125 mm*	wheel Ø 80–200 mm*

\* Other castor series with bolt hole: LRA-TPA / LKRA-TPA (page 123), LMDA-TPA (page 125), LER-TPA (page 188), LRXA-TPA / LKRXA-TPA (page 390), LEXR-TPA (page 400)

## VPA...-EL series

**Wheels with solid rubber tyre,  
with synthetic rim  
electrically conductive**

30–100 kg

**Tread and tyre hardness**

80 Shore A

**Smooth operation / floor preservation**

very good

**Rolling resistance**

good

**Wear resistance**

sufficient

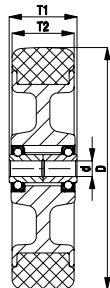

**Tyre:**

- high-quality solid rubber, hardness 80 Shore A
- very good operational comfort
- very good floor preservation, low-noise operation
- colour black

**Rim:**

- high-quality polypropylene, impact resistant
- colour black

**Other features:**

- high chemical resistance to many aggressive substances, except oils
- operating temperature: -20 °C to +60 °C, reduced load capacity over +30 °C
- electrical conductivity (ohmic resistance)  $\leq 10^4 \Omega$

**Additional details:**

- wheel series: page 60
- tread: page 52
- bearing types: page 84–85
- chemical resistance: page 51

Wheels	Wheel Ø (D) [mm]	Tyre width (T2) [mm]	Load capacity [kg]	Bearing type	Axle bore Ø (d) [mm]	Hub length (T1) [mm]
VPA 50/6K-EL	50	18	30	ball bearing	6	22.5
VPA 75/6K-EL	75	25	45	ball bearing	6	30
VPA 80/8K-EL	80	25	60	ball bearing	8	35
VPA 100/6K-EL	100	25	70	ball bearing	6	30
VPA 101/8K-EL	100	32	80	ball bearing	8	35
VPA 125/8K-EL	125	25	75	ball bearing	8	35
VPA 126/8K-EL	125	32	95	ball bearing	8	35
VPA 150/8K-EL	150	30	100	ball bearing	8	35

## Castor series



	LRA-VPA / LKRA-VPA	LPA-VPA / LKPA-VPA	LMDA-VPA	LDA-VPA
Page	128	130	131	132
Load capacity class				
Available for	wheel Ø 50–150 mm	wheel Ø 50–150 mm	wheel Ø 50–75 mm	wheel Ø 50–75 mm

## VE...-EL / V...-EL series

**Wheels with standard solid rubber tyre, with pressed steel rim electrically conductive**



50–295 kg

**Tread and tyre hardness**  
 80 Shore A

**Smooth operation / floor preservation**  
 very good

**Rolling resistance**  
 satisfactory

**Wear resistance**  
 sufficient

- Tyre:**
- standard solid rubber, hardness 80 Shore A
  - very good operational comfort
  - very good floor preservation, low-noise operation
  - colour black

- Rim:**
- pressed steel
  - zinc-plated, blue-passivated, Cr6-free

- Other features:**
- chemical resistance to many aggressive substances, except oils
  - operating temperature: -20 °C to +80 °C, reduced load capacity over +60 °C
  - electrical conductivity (ohmic resistance) ≤ 10<sup>4</sup> Ω

- Additional details:**
- wheel series: page 61–62
  - tread: page 52
  - bearing types: page 84–85
  - chemical resistance: page 51

Wheels	Wheel Ø (D) [mm]	Tyre width (T2) [mm]	Load capacity [kg]	Bearing type	Axle bore Ø (d) [mm]	Hub length (T1) [mm]
<b>VE series</b>						
VE 80/12R-EL	80	25	50	roller bearing	12	35
VE 100/12R-EL	100	30	70	roller bearing	12	45
VE 125/12R-EL	125	37.5	100	roller bearing	12	45
VE 150/20R-EL	150	40	135	roller bearing	20	60
VE 160/20R-EL	160	40	135	roller bearing	20	60
VE 180/20R-EL	180	50	170	roller bearing	20	60
VE 200/20R-EL	200	50	205	roller bearing	20	60
<b>V series</b>						
V 80/12R-EL	80	25	50	roller bearing	12	35
V 100/15R-EL	100	30	70	roller bearing	15	45
V 125/15R-EL	125	37.5	100	roller bearing	15	45
V 140/15R-EL	140	37.5	115	roller bearing	15	45
V 162/20R-EL	160	40	135	roller bearing	20	60
V 182/20R-EL	180	50	170	roller bearing	20	60
V 202/20R-EL	200	50	205	roller bearing	20	60
V 202/25R-EL	200	50	205	roller bearing	25	60
V 200/20K-EL	200	50	205	ball bearing	20	60
V 252/25R-EL	250	60	295	roller bearing	25	65
V 250/25K-EL	250	60	295	ball bearing	25	65

## Castor series



	LE-VE	LER-VE	L-V
Page	196	197	201
Load capacity class			
Available for	wheel Ø 80–200 mm*	wheel Ø 80–200 mm	wheel Ø 80–250 mm

\* Other castor series with stem: LEZ-VE (page 198)

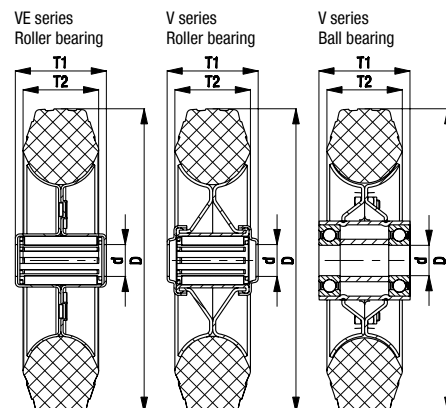

## ALEV...-EL series

**Heavy-duty wheels with elastic solid rubber tyre “Blickle EasyRoll”, with aluminium wheel centre electrically conductive**



**200–650 kg**

**Tread and tyre hardness**  
 65 Shore A

**Smooth operation / floor preservation**  
 very good

**Rolling resistance**  
 very good

**Wear resistance**  
 good

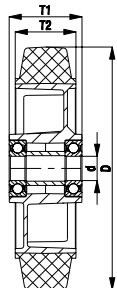

- Tyre:**
- high-quality elastic solid rubber “Blickle EasyRoll” in smooth rolling quality, hardness 65 Shore A
  - very good operational comfort
  - very good floor preservation, low-noise operation
  - low rolling resistance
  - colour black
  - vulcanised onto the wheel centre

- Wheel centre:**
- die-cast aluminium

- Other features:**
- chemical resistance to many aggressive substances, except oils
  - operating temperature: -20 °C to +80 °C, temporarily up to +100 °C, reduced load capacity over +60 °C
  - electrical conductivity (ohmic resistance)  $\leq 10^4 \Omega$

- Additional details:**
- wheel series: page 63
  - tread: page 53
  - bearing types: page 84–85
  - chemical resistance: page 51

Wheels	Wheel $\emptyset$	Wheel width	Load capacity at 4 km/h	Load capacity at 10 km/h	Bearing type	Axle bore $\emptyset$	Hub length
	(D) [mm]	(T2) [mm]	[kg]	[kg]		(d) [mm]	(T1) [mm]
ALEV 100/15K-EL	100	40	200	–	ball bearing	15	40
ALEV 125/15K-EL	125	40	250	–	ball bearing	15	45
ALEV 161/15K-EL	160	40	300	150	ball bearing	15	60
ALEV 160/20K-EL	160	50	400	200	ball bearing	20	60
ALEV 160/25K-EL	160	50	400	200	ball bearing	25	60
ALEV 200/20K-EL	200	50	500	250	ball bearing	20	60
ALEV 200/25K-EL	200	50	500	250	ball bearing	25	60
ALEV 250/20K-EL	250	50	650	320	ball bearing	20	60
ALEV 250/25K-EL	250	50	650	320	ball bearing	25	60

## Castor series



	L-ALEV	LK-ALEV	LH-ALEV	LUH-ALEV	LO-ALEV	LHD-ALEV
Page	222	223	224	225	226	227
Load capacity class						
Available for	wheel $\emptyset$ 100–250 mm	wheel $\emptyset$ 100–200 mm	wheel $\emptyset$ 100–250 mm	wheel $\emptyset$ 160–200 mm	wheel $\emptyset$ 160–250 mm	wheel $\emptyset$ 100–125 mm

## ALEV...-SG-AS series

**Heavy-duty wheels with elastic solid rubber tyre “Blickle EasyRoll”, with aluminium wheel centre antistatic, non-marking**



200–550 kg

**Tread and tyre hardness**

65 Shore A

**Smooth operation / floor preservation**

very good

**Rolling resistance**

very good

**Wear resistance**

good

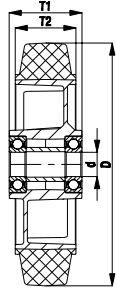

**Tyre:**

- high-quality elastic solid rubber “Blickle EasyRoll” in smooth rolling quality, hardness 65 Shore A
- very good operational comfort
- very good floor preservation, low-noise operation
- low rolling resistance
- colour grey, non-marking
- vulcanised onto the wheel centre

**Wheel centre:**

- die-cast aluminium

**Other features:**

- high chemical resistance to many aggressive substances, except oils
- operating temperature: -20 °C to +80 °C, temporarily up to +100 °C, reduced load capacity over +60 °C
- electrical conductivity (ohmic resistance)  $\leq 10^7 \Omega$

**Wheels**

Wheels	Wheel Ø (D) [mm]	Wheel width (T2) [mm]	Load capacity at 4 km/h [kg]	Load capacity at 10 km/h [kg]	Bearing type	Axle bore Ø (d) [mm]	Hub length (T1) [mm]
ALEV 100/15K-SG-AS	100	40	200	–	ball bearing	15	40
ALEV 125/15K-SG-AS	125	40	250	–	ball bearing	15	45
ALEV 160/20K-SG-AS	160	50	350	170	ball bearing	20	60
ALEV 200/20K-SG-AS	200	50	450	220	ball bearing	20	60
ALEV 200/25K-SG-AS	200	50	450	220	ball bearing	25	60
ALEV 250/20K-SG-AS	250	50	550	270	ball bearing	20	60
ALEV 250/25K-SG-AS	250	50	550	270	ball bearing	25	60

**Additional details:**

- wheel series: page 63
- tread: page 53
- bearing types: page 84–85
- chemical resistance: page 51

9

## Castor series



	L-ALEV	LK-ALEV	LH-ALEV	LUH-ALEV	LO-ALEV	LHD-ALEV
Page	222	223	224	225	226	227
Load capacity class						
Available for	wheel Ø 100–250 mm	wheel Ø 100–200 mm	wheel Ø 100–250 mm	wheel Ø 160–200 mm	wheel Ø 160–250 mm	wheel Ø 100–125 mm



## PATH...-ELS series

**Wheels with thermoplastic polyurethane tread, with nylon wheel centre, electrically conductive, non-marking**

50–325 kg

### Tread and tyre hardness

94 Shore A

### Smooth operation / floor preservation

good

### Rolling resistance

very good

### Wear resistance

very good

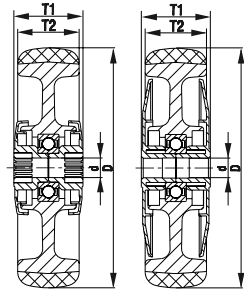

ball bearing (C) KA version      ball bearing (C) KF version



### Tread:

- high-quality thermoplastic polyurethane (TPU), hardness 94 Shore A
- low rolling and swivel resistance
- high abrasion resistance
- colour dark grey, non-marking, non-staining
- chemically-bonded inseparable connection with the wheel centre

### Wheel centre:

- high-quality nylon 6, impact resistant
- colour silver grey (thread guard: black)

### Other features:

- KA version: with synthetic thread guard, small
- KF version: with synthetic thread guard, large
- KAD version: with synthetic thread guard, small, with additional ball bearing seal
- KFD version: with synthetic thread guard, large, with additional ball bearing seal
- very high chemical resistance to many aggressive substances
- operating temperature: -20 °C to +70 °C, temporarily up to +90 °C, reduced load capacity over +35 °C
- electrical conductivity (ohmic resistance) ≤ 10<sup>4</sup> Ω

### Additional details:

- wheel series: page 61
- tread: page 55
- bearing types: page 84–85
- chemical resistance: page 51

Wheels	Wheel Ø (D) [mm]	Wheel width (T2) [mm]	Load capacity [kg]	Bearing type	Axle bore Ø (d) [mm]	Hub length (T1) [mm]
PATH 50/6KF-ELS	50	19	50	ball bearing (C)	6	23
PATH 50/6KFD-ELS	50	19	50	ball bearing (C)	6	23
PATH 75/6KF-ELS	75	25	65	ball bearing (C)	6	31
PATH 75/6KFD-ELS	75	25	65	ball bearing (C)	6	31
PATH 80/8KF-ELS	80	32	100	ball bearing (C)	8	36
PATH 80/8KFD-ELS	80	32	100	ball bearing (C)	8	36
PATH 101/8KF-ELS	100	32	130	ball bearing (C)	8	36
PATH 101/8KFD-ELS	100	32	130	ball bearing (C)	8	36
PATH 100/8KF-ELS	100	32	130	ball bearing (C)	8	46
PATH 100/8KFD-ELS	100	32	130	ball bearing (C)	8	46
PATH 100/10KF-ELS	100	32	130	ball bearing (C)	10	46
PATH 100/10KFD-ELS	100	32	130	ball bearing (C)	10	46
PATH 126/8KF-ELS	125	32	160	ball bearing (C)	8	36
PATH 126/8KFD-ELS	125	32	160	ball bearing (C)	8	36
PATH 125/8KF-ELS	125	32	160	ball bearing (C)	8	46
PATH 125/8KFD-ELS	125	32	160	ball bearing (C)	8	46
PATH 125/10KF-ELS	125	32	160	ball bearing (C)	10	46
PATH 125/10KFD-ELS	125	32	160	ball bearing (C)	10	46
PATH 160/12KAD-ELS	160	40	260	ball bearing (C)	12	62
PATH 160/12KA-ELS	160	40	260	ball bearing (C)	12	62
PATH 160/20KA-ELS	160	40	260	ball bearing (C)	20	60
PATH 160/20KAD-ELS	160	40	260	ball bearing (C)	20	60
PATH 200/12KAD-ELS	200	40	325	ball bearing (C)	12	62
PATH 200/12KA-ELS	200	40	325	ball bearing (C)	12	62
PATH 200/20KA-ELS	200	40	325	ball bearing (C)	20	60
PATH 200/20KAD-ELS	200	40	325	ball bearing (C)	20	60

## Castor series



	LPA-PATH / LKPA-PATH	LDA-PATH	LE-PATH	L-PATH	LK-PATH	LPXA-PATH / LKPXA-PATH	LEX-PATH
Page	138	140	259	261	262	395	407
Load capacity class							
Available for	wheel Ø 50–125 mm*	wheel Ø 50–75 mm*	wheel Ø 80–200 mm*	wheel Ø 80–200 mm	wheel Ø 80–200 mm	wheel Ø 50–125 mm*	wheel Ø 80–200 mm*

\* Other castor series with bolt hole: LRA-PATH / LKRA-PATH (page 137), LMDA-PATH (page 139), LER-PATH (page 260), LRXA-PATH / LKRXA-PATH (page 394), LEXR-PATH (page 408)

# ALH...-AS series

**Heavy-duty wheels**  
with **Blickle Extrathane®** polyurethane tread,  
with aluminium wheel centre, antistatic

200–1,250 kg

**Tread and tyre hardness**  
 92 Shore A

**Smooth operation / floor preservation**  
 good

**Rolling resistance**  
 very good

**Wear resistance**  
 excellent

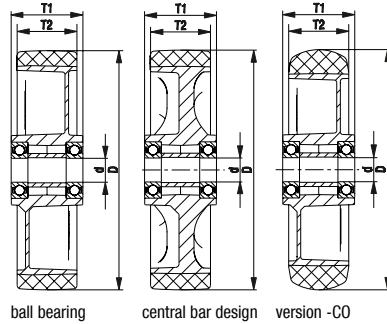

- Tread:**
- high-quality polyurethane elastomer Blickle Extrathane®, hardness 92 Shore A
  - low rolling resistance
  - high abrasion resistance
  - high cut and tear propagation resistance
  - colour grey, non-marking, non-staining
  - excellent chemical connection with the wheel centre

- Wheel centre:**
- die-cast aluminium

- Other features:**
- high chemical resistance to many aggressive substances
  - operating temperature: -20 °C to +70 °C, temporarily up to +90 °C, reduced load capacity over +40 °C
  - electrical conductivity (ohmic resistance)  $\leq 10^9 \Omega$

- Additional details:**
- wheel series: page 65
  - tread: page 55
  - bearing types: page 84–85
  - chemical resistance: page 51

Wheels	Wheel Ø (D) [mm]	Wheel width (T2) [mm]	Load capacity at 4 km/h [kg]	Load capacity at 10 km/h [kg]	Bearing type	Axle bore Ø (d) [mm]	Hub length (T1) [mm]
ALTH 80/15K-AS	80	30	200	–	ball bearing	15	35
ALTH 100/15K-AS	100	40	350	–	ball bearing	15	45
ALTH 101/15K-AS *	100	40	420	–	ball bearing	15	40
ALTH 101/15K-AS-CO *	100	40	420	–	ball bearing	15	40
ALTH 125/15K-AS	125	40	550	–	ball bearing	15	45
ALTH 125/15K-AS-CO	125	40	550	–	ball bearing	15	45
ALTH 127/20K-AS	125	54	750	370	ball bearing	20	60
ALTH 151/15K-AS	150	40	400	200	ball bearing	15	60
ALTH 150/20K-AS	150	50	650	320	ball bearing	20	60
ALTH 152/20K-AS *	150	54	900	450	ball bearing	20	60
ALTH 160/20K-AS	160	50	750	370	ball bearing	20	60
ALTH 160/20K-AS-CO	160	50	750	300	ball bearing	20	60
ALTH 162/20K-AS *	160	50	950	470	ball bearing	20	60
ALTH 180/20K-AS	180	50	700	350	ball bearing	20	60
ALTH 200/20K-AS	200	50	800	400	ball bearing	20	60
ALTH 200/20K-AS-CO	200	50	800	320	ball bearing	20	60
ALTH 200/25K-AS	200	50	800	400	ball bearing	25	60
ALTH 200/25K-AS-CO	200	50	800	320	ball bearing	25	60
ALTH 202/20K-AS *	200	50	1,000	500	ball bearing	20	60
ALTH 250/25K-AS	250	60	1,000	500	ball bearing	25	70
ALTH 252/25K-AS *	250	60	1,250	620	ball bearing	25	70

\*With heavy-duty wheel centre, reinforced design

9

## Castor series



	L-ALTH	LK-ALTH	LKR-ALTH	LH-ALTH	LHZ-ALTH	LUH-ALTH	LO-ALTH
Page	275	276	277	278	279	280	281
Load capacity class							
Available for	wheel Ø 80–250 mm	wheel Ø 80–200 mm	wheel Ø 80, 100, 125x40 mm	wheel Ø 80–250 mm	wheel Ø 125x54, 160, 200 mm	wheel Ø 125x54, 150, 160, 200 mm	wheel Ø 125x54, 150, 160, 200, 250 mm

## ALST...-AS series

**Heavy-duty wheels**  
with **Blickle Softhane®** polyurethane tread,  
with aluminium wheel centre, antistatic

320–750 kg

**Tread and tyre hardness**

75 Shore A

**Smooth operation / floor preservation**

very good

**Rolling resistance**

very good

**Wear resistance**

very good

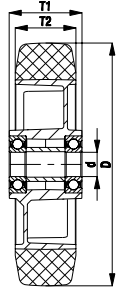

**Tread:**

- high-quality polyurethane elastomer Blickle Softhane®, hardness 75 Shore A
- extra-thick elastic tread for excellent operational comfort
- very good floor preservation, low-noise operation
- low rolling resistance
- high abrasion resistance
- high cut and tear propagation resistance
- colour grey, non-marking, non-staining
- excellent chemical connection with the wheel centre

**Wheels**

Wheels	Wheel Ø (D) [mm]	Wheel width (T2) [mm]	Load capacity at 4 km/h [kg]	Load capacity at 10 km/h [kg]	Bearing type	Axle bore Ø (d) [mm]	Hub length (T1) [mm]
ALST 100/15K-AS	100	40	320	–	ball bearing	15	40
ALST 125/15K-AS	125	40	370	–	ball bearing	15	45
ALST 127/20K-AS	125	54	450	180	ball bearing	20	60
ALST 150/20K-AS	150	50	500	200	ball bearing	20	60
ALST 160/20K-AS	160	50	580	230	ball bearing	20	60
ALST 200/20K-AS	200	50	750	300	ball bearing	20	60

**Wheel centre:**

- die-cast aluminium

**Other features:**

- high chemical resistance to many aggressive substances
- operating temperature: -20 °C to +70 °C, temporarily up to +90 °C, reduced load capacity over +40 °C
- electrical conductivity (ohmic resistance) ≤ 10<sup>7</sup> Ω

**Additional details:**

- wheel series: page 66
- tread: page 55
- bearing types: page 84–85
- chemical resistance: page 51

### Castor series



	L-ALST	LK-ALST	LKR-ALST	LH-ALST	LUH-ALST	LO-ALST
Page	295	296	297	298	299	300
Load capacity class						
Available for	wheel Ø 100–200 mm	wheel Ø 100–200 mm	wheel Ø 100–125x40 mm	wheel Ø 100–200 mm	wheel Ø 125x54–200 mm	wheel Ø 125x54–200 mm

## PP...-EL series

### Polypropylene wheels electrically conductive

160–450 kg

**Tread and tyre hardness**  
 60 Shore D

**Smooth operation / floor preservation**  
 satisfactory

**Rolling resistance**  
 very good

**Wear resistance**  
 satisfactory

**Wheel:**

- high-quality polypropylene, impact resistant, hardness 60 Shore D
- low rolling and swivel resistance
- colour black

**Other features:**

- KA version: with synthetic thread guard, small
- high chemical resistance to many aggressive substances
- operating temperature: -20 °C to +60 °C, reduced load capacity over +30 °C
- electrical conductivity (ohmic resistance)  $\leq 10^4 \Omega$

**Additional details:**

- wheel series: page 69
- tread: page 57
- bearing types: page 84–85
- chemical resistance: page 51



Wheels	Wheel Ø	Wheel width	Load capacity [kg]	Bearing type	Axle bore Ø	Hub length
	(D) [mm]	(T2) [mm]			(d) [mm]	(T1) [mm]
PP 100/8KA-EL	100	37	160	ball bearing (C)	8	46
PP 125/8KA-EL	125	40	200	ball bearing (C)	8	46
PP 150/20K-EL	150	50	300	ball bearing	20	60
PP 200/20K-EL	200	50	450	ball bearing	20	60

9

### Castor series



	LE-PP	LER-PP	L-PP
Page	337	338	339
Load capacity class			
Available for	all	all	all

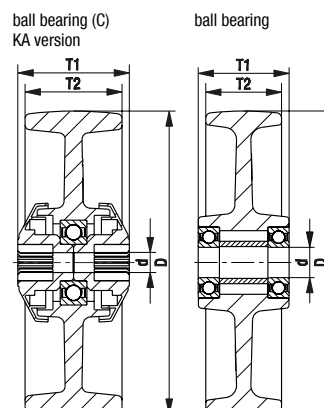

## PO...-ELS series

### Nylon wheels

electrically conductive, non-marking



220–600 kg

**Tread and tyre hardness**

70 Shore D

**Smooth operation / floor preservation**

satisfactory

**Rolling resistance**

excellent

**Wear resistance**

good

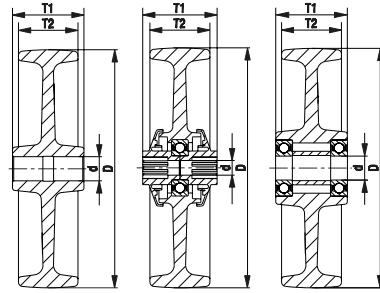

plain bore      ball bearing (C) KA version      ball bearing

**Wheel:**

- high-quality nylon 6, impact resistant, hardness 70 Shore D
- excellent rolling and swivel resistance
- easy operation on smooth surfaces
- high abrasion resistance
- colour grey, non-marking

**Other features:**

- KA version: with synthetic thread guard, small
- high chemical resistance to many aggressive substances
- operating temperature: -20 °C to +80 °C, reduced load capacity over +35 °C
- electrical conductivity (ohmic resistance)  $\leq 10^4 \Omega$

**Additional details:**

- wheel series: page 69
- tread: page 57
- bearing types: page 84–85
- chemical resistance: page 51

Wheels	Wheel Ø (D) [mm]	Wheel width (T2) [mm]	Load capacity [kg]	Bearing type	Axle bore Ø (d) [mm]	Hub length (T1) [mm]
PO 80/12G-ELS	80	32	220	plain bore	12	35
PO 80/8KA-ELS	80	32	220	ball bearing (C)	8	36
PO 100/12G-ELS	100	37	280	plain bore	12	45
PO 100/15G-ELS	100	37	280	plain bore	15	45
PO 100/8KA-ELS	100	37	280	ball bearing (C)	8	46
PO 100/10KA-ELS	100	37	280	ball bearing (C)	10	46
PO 125/12G-ELS	125	40	300	plain bore	12	45
PO 125/15G-ELS	125	40	300	plain bore	15	45
PO 125/8KA-ELS	125	40	300	ball bearing (C)	8	46
PO 125/10KA-ELS	125	40	300	ball bearing (C)	10	46
PO 150/20G-ELS	150	50	400	plain bore	20	60
PO 150/20K-ELS	150	50	400	ball bearing	20	60
PO 160/20G-ELS	160	50	450	plain bore	20	60
PO 160/20K-ELS	160	50	450	ball bearing	20	60
PO 200/20G-ELS	200	50	600	plain bore	20	60
PO 200/20K-ELS	200	50	600	ball bearing	20	60

## Castor series



	LE-PO / LEX-PO	LER-PO / LEXR-PO	L-PO / LX-PO	LK-PO	LH-PO	LUH-PO	LO-PO
Page	345 / 417	346 / 418	348 / 420	350	352	353	354
Load capacity class							
Available for	wheel Ø 80–200 mm	wheel Ø 80–200 mm*	wheel Ø 80–200 mm	wheel Ø 100–200 mm	wheel Ø 100–200 mm	wheel Ø 150–200 mm	wheel Ø 150–200 mm

\* Other castor series with stem: LEZ-PO (page 347), LEXZ-PO (page 419)

# G series

## Cast iron wheels



250–1,400 kg

**Tread and tyre hardness**  
 180–220 HB

**Smooth operation / floor preservation**  
 sufficient

**Rolling resistance**  
 excellent

**Wear resistance**  
 excellent

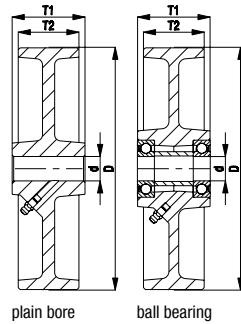

plain bore

ball bearing

**Wheel:**

- rugged grey cast iron, hardness 180–220 HB
- with grease nipple
- extremely low rolling and swivel resistance
- outstanding wear resistance
- machined tread and edges
- lacquered, colour silver

**Other features:**

- chemical resistance to many aggressive substances
- operating temperature:  
 plain bore version: -100 °C to +600 °C  
 ball bearing version: ("K"): -20 °C to +120 °C  
 ball bearing version: ("IK"): -30 °C to +300 °C
- consider the surface pressure on sensitive floors due to high point loads
- provide adequate lubrication on a regular basis for plain bore version
- to be lubricated according to the application temperature
- electrical conductivity (ohmic resistance)  $\leq 10^4 \Omega$

**Additional details:**

- wheel series: page 70
- tread: page 59
- bearing types: page 84–85
- chemical resistance: page 51

Wheels	Wheel Ø (D) [mm]	Wheel width (T2) [mm]	Load capacity up to +70 °C [kg]	Bearing type	Axle bore Ø (d) [mm]	Hub length (T1) [mm]
G 80/12G	80	25	250	plain bore	12	35
G 80/15G	80	25	250	plain bore	15	35
G 100/15G	100	35	400	plain bore	15	45
G 100/15IK	100	35	400	ball bearing	15	40
G 100/15K	100	35	400	ball bearing	15	40
G 125/15G	125	35	450	plain bore	15	45
G 125/15IK	125	35	450	ball bearing	15	45
G 125/15K	125	35	450	ball bearing	15	45
G 127/20G	125	50	750	plain bore	20	60
G 127/20IK	125	50	750	ball bearing	20	60
G 127/20K	125	50	750	ball bearing	20	60
G 150/20G	150	50	900	plain bore	20	60
G 150/20IK	150	50	900	ball bearing	20	60
G 150/20K	150	50	900	ball bearing	20	60
G 200/20G	200	50	1,100	plain bore	20	60
G 200/20IK	200	50	1,000	ball bearing	20	60
G 200/20K	200	50	1,100	ball bearing	20	60
G 250/25G	250	60	1,400	plain bore	25	65
G 250/25IK	250	60	1,300	ball bearing	25	70
G 250/25K	250	60	1,400	ball bearing	25	70

9

### Castor series



	L-G	LK-G	LH-G	LO-G	LS-G	LI-G	LI0-G
Page	377	378	379	380	381	469	470
Load capacity class							
Available for	wheel Ø 80–200 mm	wheel Ø 80–200 mm	all	wheel Ø 125x50–250 mm	wheel Ø 125x50–250 mm	wheel Ø 80–200 mm*	wheel Ø 125x50–250 mm*

\* Plain bore version and ball bearing version "IK"

## SVS series

### Super heavy-duty solid steel wheels



750–15,000 kg

<b>Tread and tyre hardness</b>	190–230 HB
<b>Smooth operation / floor preservation</b>	sufficient
<b>Rolling resistance</b>	excellent
<b>Wear resistance</b>	excellent

#### Wheel:

- heat-treatable steel, machined, hardness 190–230 HB
- slightly crowned tread
- lightly-oiled surface
- extremely low rolling resistance
- easy operation on smooth surfaces
- outstanding wear resistance
- extremely high static and dynamic load capacity

#### Other features:

- chemical resistance to many aggressive substances
- operating temperature: -20 °C to +120 °C
- consider the surface pressure on sensitive floors due to high point loads
- electrical conductivity (ohmic resistance)  $\leq 10^4 \Omega$

#### Additional details:

- wheel series: page 70
- tread: page 59
- bearing types: page 84–85
- chemical resistance: page 51

Wheels	Wheel $\emptyset$ (D) [mm]	Wheel width (T2) [mm]	Load capacity [kg]	Bearing type	Axle bore $\emptyset$ (d) [mm]	Hub length (T1) [mm]
<b>SVS 65/20K</b>	65	40	750	ball bearing	20	45
<b>SVS 80/20K</b>	80	40	1,100	ball bearing	20	45
<b>SVS 100/25K</b>	100	40	1,700	ball bearing	25	45
<b>SVS 127/30K</b>	125	55	2,750	ball bearing	30	60
<b>SVS 150/45K</b>	150	55	4,000	ball bearing	45	60
<b>SVS 201/50K</b>	200	55	6,000	ball bearing	50	60
<b>SVS 200/60K</b>	200	80	7,000	ball bearing	60	90
<b>SVS 250/70K</b>	250	65	10,000	ball bearing	70	75
<b>SVS 300/100K</b>	300	90	15,000	ball bearing	100	100

Other dimensions available upon request

## Castor series



	LH-SVS	LS-SVS
Page	383	384
Load capacity class		
Available for	wheel $\emptyset$ 65–125 mm	wheel $\emptyset$ 100–300 mm

