

Nylon and polypropylene wheels and castors



6

Selection tool

Nylon and polypropylene wheels and castors



Series	PPN	PP	POW
Tread / wheel centre	Polypropylene		Nylon with elastic solid rubber pads
Tread and tyre hardness	60 Shore D	60 Shore D	70 Shore D
Non-marking	✓	–	✓
Electrical conductivity	optional (PP series)	optional	–
Wheel Ø	60–200 mm	60–200 mm	100–125 mm
Load capacity up to	450 kg	450 kg	220 kg
Low-noise operation	–	–	✓
Use on suitable concrete floors	✓	✓	✓
Chemical resistance	■■■■■	■■■■■	■■■□□
Use in wet areas	■■■■■	■■■■■	■■■□□
For a description of the wheel, refer to	page 332	page 336	page 340
For information about swivel and fixed castors, refer to	page 333–335	page 337–339	page 341–342

■■■■■ excellent

■■■■ very good

■■■ good

■■ satisfactory

■ adequate

✓ yes – no

PPN series

Polypropylene wheels, natural white



80–450 kg

Tread and tyre hardness



60 Shore D

Smooth operation / floor preservation



satisfactory

Rolling resistance



very good

Wear resistance



satisfactory

Wheel:

- high-quality polypropylene, impact resistant, hardness 60 Shore D
- low rolling and swivel resistance
- colour natural white

Other features:

- high chemical resistance to many aggressive substances
- operating temperature: -20 °C to +60 °C, reduced load capacity over +30 °C

Additional details:

- wheel series: page 68
- tread: page 57
- bearing types: page 84–85
- chemical resistance: page 51

Wheels	Wheel Ø (D) [mm]	Wheel width (T2) [mm]	Load capacity [kg]	Bearing type	Axle bore Ø (d) [mm]	Hub length (T1) [mm]
PPN 60/12G	60	29	80	plain bore	12	35
PPN 80/12G	80	32	120	plain bore	12	35
PPN 80/12R	80	32	120	roller bearing	12	35
PPN 100/12G	100	37	160	plain bore	12	45
PPN 100/12R	100	37	160	roller bearing	12	45
PPN 125/12G	125	40	200	plain bore	12	45
PPN 125/12R	125	40	200	roller bearing	12	45
PPN 150/20G	150	50	300	plain bore	20	60
PPN 150/20R	150	50	300	roller bearing	20	60
PPN 200/20G	200	50	450	plain bore	20	60
PPN 200/20R	200	50	450	roller bearing	20	60

For other dimensions, see wheel series PO on page 343–344

6

Versions / options



	electrically conductive version, colour black	with stainless steel roller bearing in the wheel hub	colour black
Technical description page	434	84	69
Product code suffix	PP...-EL series	-XR	PP series
Available for	see page 336	upon request	all see page 336

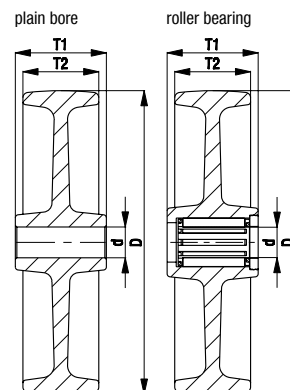

LE-PPN, B-PPN series

Pressed steel castors with top plate, with polypropylene wheel, natural white



80–300 kg

Bracket: LE/B series

- pressed steel, zinc-plated, blue-passivated, Cr6-free

Swivel bracket:

- double ball bearing in the swivel head
- swivel head seal
- minimum swivel head play and smooth rolling characteristic and increased service life due to the special dynamic Blickle riveting process

Wheel: PPN series

- high-quality polypropylene, impact resistant, hardness 60 Shore D, colour natural white

Additional details:

- bracket series: page 90
- brakes: page 112–113
- wheel series: page 332
- bearing types: page 84–85

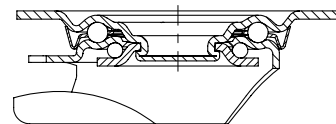

Swivel castors	Fixed castors	Swivel castors with "stop-fix" brake	Wheel Ø [mm]	Wheel width [mm]	Load capacity [kg]	Bearing type	Total height [mm]	Plate size [mm]	Bolt hole spacing [mm]	Bolt hole Ø [mm]	Offset swivel castor [mm]
LE-PPN 60G	B-PPN 60G		60	29	80	plain bore	80	100 x 85	80 x 60	9	35
LE-PPN 80G	B-PPN 80G	LE-PPN 80G-FI	80	32	120	plain bore	102	100 x 85	80 x 60	9	38
LE-PPN 80R	B-PPN 80R	LE-PPN 80R-FI	80	32	120	roller bearing	102	100 x 85	80 x 60	9	38
LE-PPN 100G	B-PPN 100G	LE-PPN 100G-FI	100	37	150	plain bore	125	100 x 85	80 x 60	9	36
LE-PPN 100R	B-PPN 100R	LE-PPN 100R-FI	100	37	150	roller bearing	125	100 x 85	80 x 60	9	36
LE-PPN 125G	B-PPN 125G	LE-PPN 125G-FI	125	40	150	plain bore	150	100 x 85	80 x 60	9	38
LE-PPN 125R	B-PPN 125R	LE-PPN 125R-FI	125	40	150	roller bearing	150	100 x 85	80 x 60	9	38
LE-PPN 150G	B-PPN 150G	LE-PPN 150G-FI	150	50	300	plain bore	190	140 x 110	105 x 75–80	11	54
LE-PPN 150R	B-PPN 150R	LE-PPN 150R-FI	150	50	300	roller bearing	190	140 x 110	105 x 75–80	11	54
LE-PPN 200G	B-PPN 200G	LE-PPN 200G-FI	200	50	300	plain bore	235	140 x 110	105 x 75–80	11	54
LE-PPN 200R	B-PPN 200R	LE-PPN 200R-FI	200	50	300	roller bearing	235	140 x 110	105 x 75–80	11	54

Versions / options



	electrically conductive version, colour black	with thread guard, pressed steel, zinc-plated	with "stop-top" brake	directional lock (separate) 1 x 360°	directional lock (separate) 1 x 360°	with steel foot guard
Technical description page	434	116	112	115	115	116
Product code suffix	PP...-EL series	-FA	-ST	RI-03.01	RI-03.03	-FS
Available for	see page 337	wheel Ø 80–200 mm	wheel Ø 150–200 mm	wheel Ø 100–125 mm*	wheel Ø 150–200 mm*	wheel Ø 100–200 mm upon request

* Only for swivel castors without brake or swivel castor with "stop-top" brake upon request

LER-PPN series

Pressed steel castors with bolt hole, with polypropylene wheel, natural white



80–300 kg

Bracket: LER series

- pressed steel, zinc-plated, blue-passivated, Cr6-free
- double ball bearing in the swivel head
- strong central kingpin
- minimum swivel head play and smooth rolling characteristic and increased service life due to the special dynamic Blickle riveting process

Wheel: PPN series

- high-quality polypropylene, impact resistant, hardness 60 Shore D, colour natural white

Additional details:

- bracket series: page 91
- brakes: page 112–113
- wheel series: page 332
- bearing types: page 84–85

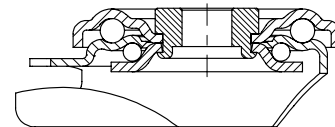

6

Swivel castors	Swivel castors with "stop-fix" brake	Wheel Ø [mm]	Wheel width [mm]	Load capacity [kg]	Bearing type	Total height [mm]	Plate Ø [mm]	Bolt hole Ø [mm]	Offset swivel castor [mm]
LER-PPN 60G		60	29	80	plain bore	80	70	13	35
LER-PPN 80G	LER-PPN 80G-FI	80	32	120	plain bore	102	70	13	38
LER-PPN 80R	LER-PPN 80R-FI	80	32	120	roller bearing	102	70	13	38
LER-PPN 100G	LER-PPN 100G-FI	100	37	150	plain bore	125	70	13	36
LER-PPN 100R	LER-PPN 100R-FI	100	37	150	roller bearing	125	70	13	36
LER-PPN 125G	LER-PPN 125G-FI	125	40	150	plain bore	150	70	13	38
LER-PPN 125R	LER-PPN 125R-FI	125	40	150	roller bearing	150	70	13	38
LER-PPN 150G	LER-PPN 150G-FI	150	50	300	plain bore	190	88	13	54
LER-PPN 150R	LER-PPN 150R-FI	150	50	300	roller bearing	190	88	13	54
LER-PPN 200G	LER-PPN 200G-FI	200	50	300	plain bore	235	88	13	54
LER-PPN 200R	LER-PPN 200R-FI	200	50	300	roller bearing	235	88	13	54

Versions / options



	electrically conductive version, colour black	with thread guard, pressed steel, zinc-plated	with steel foot guard	truck lock
Technical description page	434	116	116	114
Product code suffix	PP...-EL series	-FA	-FS	FF 100-1 / FF 125-1
Available for	see page 338	wheel Ø 80–200 mm	wheel Ø 100–200 mm upon request	wheel Ø 100+125 mm

L-PPN, B-PPN series

Pressed steel castors, medium-duty version, with top plate, with polypropylene wheel, natural white



120–400 kg

Bracket: L/B series

- pressed steel, zinc-plated, blue-passivated, Cr6-free

Swivel bracket:

- double ball bearing in the swivel head
- strong central kingpin (from wheel Ø 150 mm)
- swivel head seal
- minimum swivel head play and smooth rolling characteristic and increased service life due to the special dynamic Blickle riveting process

Wheel: PPN series

- high-quality polypropylene, impact resistant, hardness 60 Shore D, colour natural white

Additional details:

- bracket series: page 91
- brakes: page 112–113
- wheel series: page 332
- bearing types: page 84–85

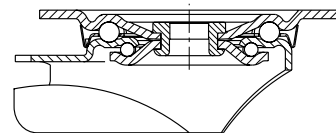

Swivel castors	Fixed castors	Swivel castors with "stop-fix" brake	Wheel Ø [mm]	Wheel width [mm]	Load capacity [kg]	Bearing type	Total height [mm]	Plate size [mm]	Bolt hole spacing [mm]	Bolt hole Ø [mm]	Offset swivel castor [mm]
L-PPN 80G	B-PPN 80G	L-PPN 80G-FI	80	32	120	plain bore	102	100 x 85	80 x 60	9	38
L-PPN 80R	B-PPN 80R	L-PPN 80R-FI	80	32	120	roller bearing	102	100 x 85	80 x 60	9	38
L-PPN 100G	B-PPN 100G	L-PPN 100G-FI	100	37	160	plain bore	125	100 x 85	80 x 60	9	36
L-PPN 100R	B-PPN 100R	L-PPN 100R-FI	100	37	160	roller bearing	125	100 x 85	80 x 60	9	36
L-PPN 125G	B-PPN 125G	L-PPN 125G-FI	125	40	200	plain bore	150	100 x 85	80 x 60	9	38
L-PPN 125R	B-PPN 125R	L-PPN 125R-FI	125	40	200	roller bearing	150	100 x 85	80 x 60	9	38
L-PPN 150G	B-PPN 150G	L-PPN 150G-FI	150	50	300	plain bore	190	140 x 110	105 x 75–80	11	60
L-PPN 150R	B-PPN 150R	L-PPN 150R-FI	150	50	300	roller bearing	190	140 x 110	105 x 75–80	11	60
L-PPN 200G	B-PPN 200G	L-PPN 200G-FI	200	50	400	plain bore	235	140 x 110	105 x 75–80	11	65
L-PPN 200R	B-PPN 200R	L-PPN 200R-FI	200	50	400	roller bearing	235	140 x 110	105 x 75–80	11	65

Versions / options



	electrically conductive version, colour black	with thread guard, pressed steel, zinc-plated	with "stop-top" brake	directional lock (separate) 1 x 360°	directional lock (separate) 1 x 360°	with steel foot guard
Technical description page	434	116	112	115	115	116
Product code suffix	PP...-EL series	-FA	-ST	RI-03.01	RI-05.03	-FS
Available for	see page 339	all	all	wheel Ø 100–125 mm*	wheel Ø 150–200 mm*	wheel Ø 100–200 mm upon request

* Only for swivel castors without brake or swivel castor with "stop-top" brake upon request

PP series

Polypropylene wheels, black



80–450 kg

Tread and tyre hardness
 60 Shore D

Smooth operation / floor preservation
 satisfactory

Rolling resistance
 very good

Wear resistance
 satisfactory

- Wheel:**
- high-quality polypropylene, impact resistant, hardness 60 Shore D
 - low rolling and swivel resistance
 - colour black

- Other features:**
- KA version: with synthetic thread guard, small
 - high chemical resistance to many aggressive substances
 - operating temperature: -20 °C to +60 °C, reduced load capacity over +30 °C

- Additional details:**
- wheel series: page 69
 - tread: page 57
 - bearing types: page 84–85
 - chemical resistance: page 51

Wheels	Wheel Ø (D) [mm]	Wheel width (T2) [mm]	Load capacity [kg]	Bearing type	Axle bore Ø (d) [mm]	Hub length (T1) [mm]
PP 60/12G	60	29	80	plain bore	12	35
PP 80/12G	80	32	120	plain bore	12	35
PP 80/12R	80	32	120	roller bearing	12	35
PP 100/12G	100	37	160	plain bore	12	45
PP 100/12R	100	37	160	roller bearing	12	45
PP 100/8KA	100	37	160	ball bearing (C)	8	46
PP 125/12G	125	40	200	plain bore	12	45
PP 125/12R	125	40	200	roller bearing	12	45
PP 125/8KA	125	40	200	ball bearing (C)	8	46
PP 150/20G	150	50	300	plain bore	20	60
PP 150/20R	150	50	300	roller bearing	20	60
PP 150/20K	150	50	300	ball bearing	20	60
PP 200/20G	200	50	450	plain bore	20	60
PP 200/20R	200	50	450	roller bearing	20	60
PP 200/20K	200	50	450	ball bearing	20	60

6

Versions / options



	electrically conductive version, colour black	with stainless steel roller bearing in the wheel hub	colour natural white
Technical description page	434	84	332
Product code suffix	-EL	-XR	PPN series
Available for	all ball bearing versions	upon request	see page 332

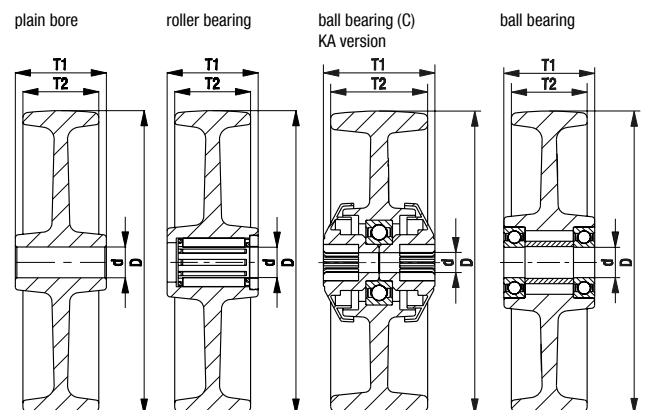

LE-PP, B-PP series

Pressed steel castors with top plate, with polypropylene wheel, black

80–300 kg

Bracket: LE/B series

- pressed steel, zinc-plated, blue-passivated, Cr6-free

Swivel bracket:

- double ball bearing in the swivel head
- swivel head seal
- minimum swivel head play and smooth rolling characteristic and increased service life due to the special dynamic Blickle riveting process

Wheel: PP series

- high-quality polypropylene, impact resistant, hardness 60 Shore D, colour black

Additional details:

- bracket series: page 90
- brakes: page 112–113
- wheel series: page 336
- bearing types: page 84–85

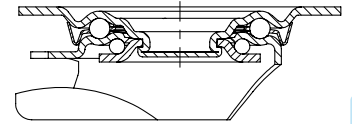

Swivel castors	Fixed castors	Swivel castors with "stop-fix" brake	Wheel Ø [mm]	Wheel width [mm]	Load capacity [kg]	Bearing type	Total height [mm]	Plate size [mm]	Bolt hole spacing [mm]	Bolt hole Ø [mm]	Offset swivel castor [mm]
LE-PP 60G	B-PP 60G		60	29	80	plain bore	80	100 x 85	80 x 60	9	35
LE-PP 80G	B-PP 80G	LE-PP 80G-FI	80	32	120	plain bore	102	100 x 85	80 x 60	9	38
LE-PP 80R	B-PP 80R	LE-PP 80R-FI	80	32	120	roller bearing	102	100 x 85	80 x 60	9	38
LE-PP 100G	B-PP 100G	LE-PP 100G-FI	100	37	150	plain bore	125	100 x 85	80 x 60	9	36
LE-PP 100R	B-PP 100R	LE-PP 100R-FI	100	37	150	roller bearing	125	100 x 85	80 x 60	9	36
LE-PP 100KA	B-PP 100KA	LE-PP 100KA-FI	100	37	150	ball bearing (C)	125	100 x 85	80 x 60	9	36
LE-PP 125G	B-PP 125G	LE-PP 125G-FI	125	40	150	plain bore	150	100 x 85	80 x 60	9	38
LE-PP 125R	B-PP 125R	LE-PP 125R-FI	125	40	150	roller bearing	150	100 x 85	80 x 60	9	38
LE-PP 125KA	B-PP 125KA	LE-PP 125KA-FI	125	40	150	ball bearing (C)	150	100 x 85	80 x 60	9	38
LE-PP 150G	B-PP 150G	LE-PP 150G-FI	150	50	300	plain bore	190	140 x 110	105 x 75–80	11	54
LE-PP 150R	B-PP 150R	LE-PP 150R-FI	150	50	300	roller bearing	190	140 x 110	105 x 75–80	11	54
LE-PP 150K	B-PP 150K	LE-PP 150K-FI	150	50	300	ball bearing	190	140 x 110	105 x 75–80	11	54
LE-PP 200G	B-PP 200G	LE-PP 200G-FI	200	50	300	plain bore	235	140 x 110	105 x 75–80	11	54
LE-PP 200R	B-PP 200R	LE-PP 200R-FI	200	50	300	roller bearing	235	140 x 110	105 x 75–80	11	54
LE-PP 200K	B-PP 200K	LE-PP 200K-FI	200	50	300	ball bearing	235	140 x 110	105 x 75–80	11	54

Versions / options



	electrically conductive version, colour black	with thread guard, pressed steel, zinc-plated	with "stop-top" brake	directional lock (separate) 1 x 360°	directional lock (separate) 1 x 360°	with steel foot guard
Technical description page	434	116	112	115	115	116
Product code suffix	-EL	-FA	-ST	RI-03.01	RI-03.03	-FS
Available for	all ball bearing versions	wheel Ø 80–200 mm	wheel Ø 150–200 mm	wheel Ø 100–125 mm*	wheel Ø 150–200 mm*	wheel Ø 100–200 mm upon request

* Only for swivel castors without brake or swivel castor with "stop-top" brake upon request

LER-PP series

Pressed steel castors with bolt hole, with polypropylene wheel, black



80–300 kg

Bracket: LER series

- pressed steel, zinc-plated, blue-passivated, Cr6-free
- double ball bearing in the swivel head
- strong central kingpin
- minimum swivel head play and smooth rolling characteristic and increased service life due to the special dynamic Blickle riveting process

Wheel: PP series

- high-quality polypropylene, impact resistant, hardness 60 Shore D, colour black

Additional details:

- bracket series: page 91
- brakes: page 112–113
- wheel series: page 336
- bearing types: page 84–85

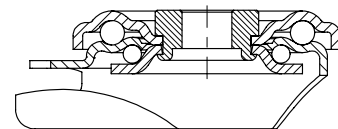

6

Swivel castors	Swivel castors with "stop-fix" brake	Wheel Ø [mm]	Wheel width [mm]	Load capacity [kg]	Bearing type	Total height [mm]	Plate Ø [mm]	Bolt hole Ø [mm]	Offset swivel castor [mm]
LER-PP 60G		60	29	80	plain bore	80	70	13	35
LER-PP 80G	LER-PP 80G-FI	80	32	120	plain bore	102	70	13	38
LER-PP 80R	LER-PP 80R-FI	80	32	120	roller bearing	102	70	13	38
LER-PP 100G	LER-PP 100G-FI	100	37	150	plain bore	125	70	13	36
LER-PP 100R	LER-PP 100R-FI	100	37	150	roller bearing	125	70	13	36
LER-PP 100KA	LER-PP 100KA-FI	100	37	150	ball bearing (C)	125	70	13	36
LER-PP 125G	LER-PP 125G-FI	125	40	150	plain bore	150	70	13	38
LER-PP 125R	LER-PP 125R-FI	125	40	150	roller bearing	150	70	13	38
LER-PP 125KA	LER-PP 125KA-FI	125	40	150	ball bearing (C)	150	70	13	38
LER-PP 150G	LER-PP 150G-FI	150	50	300	plain bore	190	88	13	54
LER-PP 150R	LER-PP 150R-FI	150	50	300	roller bearing	190	88	13	54
LER-PP 150K	LER-PP 150K-FI	150	50	300	ball bearing	190	88	13	54
LER-PP 200G	LER-PP 200G-FI	200	50	300	plain bore	235	88	13	54
LER-PP 200R	LER-PP 200R-FI	200	50	300	roller bearing	235	88	13	54
LER-PP 200K	LER-PP 200K-FI	200	50	300	ball bearing	235	88	13	54

Versions / options



	electrically conductive version, colour black	with thread guard, pressed steel, zinc-plated	with steel foot guard	truck lock
Technical description page	434	116	116	114
Product code suffix	-EL	-FA	-FS	FF 100-1 / FF 125-1
Available for	all ball bearing versions	wheel Ø 80–200 mm	wheel Ø 100–200 mm upon request	wheel Ø 100+125 mm

L-PP, B-PP series

Pressed steel castors, medium-duty version, with top plate, with polypropylene wheel, black



120–400 kg

Bracket: L/B series

- pressed steel, zinc-plated, blue-passivated, Cr6-free

Swivel bracket:

- double ball bearing in the swivel head
- strong central kingpin (from wheel Ø 150 mm)
- swivel head seal
- minimum swivel head play and smooth rolling characteristic and increased service life due to the special dynamic Blickle riveting process

Wheel: PP series

- high-quality polypropylene, impact resistant, hardness 60 Shore D, colour black

Additional details:

- bracket series: page 91
- brakes: page 112–113
- wheel series: page 336
- bearing types: page 84–85

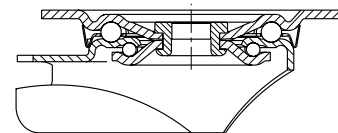

Swivel castors	Fixed castors	Swivel castors with "stop-fix" brake	Wheel Ø [mm]	Wheel width [mm]	Load capacity [kg]	Bearing type	Total height [mm]	Plate size [mm]	Bolt hole spacing [mm]	Bolt hole Ø [mm]	Offset swivel castor [mm]
L-PP 80G	B-PP 80G	L-PP 80G-FI	80	32	120	plain bore	102	100 x 85	80 x 60	9	38
L-PP 80R	B-PP 80R	L-PP 80R-FI	80	32	120	roller bearing	102	100 x 85	80 x 60	9	38
L-PP 100G	B-PP 100G	L-PP 100G-FI	100	37	160	plain bore	125	100 x 85	80 x 60	9	36
L-PP 100R	B-PP 100R	L-PP 100R-FI	100	37	160	roller bearing	125	100 x 85	80 x 60	9	36
L-PP 100KA	B-PP 100KA	L-PP 100KA-FI	100	37	160	ball bearing (C)	125	100 x 85	80 x 60	9	36
L-PP 125G	B-PP 125G	L-PP 125G-FI	125	40	200	plain bore	150	100 x 85	80 x 60	9	38
L-PP 125R	B-PP 125R	L-PP 125R-FI	125	40	200	roller bearing	150	100 x 85	80 x 60	9	38
L-PP 125KA	B-PP 125KA	L-PP 125KA-FI	125	40	200	ball bearing (C)	150	100 x 85	80 x 60	9	38
L-PP 150G	B-PP 150G	L-PP 150G-FI	150	50	300	plain bore	190	140 x 110	105 x 75–80	11	60
L-PP 150R	B-PP 150R	L-PP 150R-FI	150	50	300	roller bearing	190	140 x 110	105 x 75–80	11	60
L-PP 150K	B-PP 150K	L-PP 150K-FI	150	50	300	ball bearing	190	140 x 110	105 x 75–80	11	60
L-PP 200G	B-PP 200G	L-PP 200G-FI	200	50	400	plain bore	235	140 x 110	105 x 75–80	11	65
L-PP 200R	B-PP 200R	L-PP 200R-FI	200	50	400	roller bearing	235	140 x 110	105 x 75–80	11	65
L-PP 200K	B-PP 200K	L-PP 200K-FI	200	50	400	ball bearing	235	140 x 110	105 x 75–80	11	65

Versions / options



	electrically conductive version, colour black	with thread guard, pressed steel, zinc-plated	with "stop-top" brake	directional lock (separate) 1 x 360°	directional lock (separate) 1 x 360°	with steel foot guard
Technical description page	434	116	112	115	115	116
Product code suffix	-EL	-FA	-ST	RI-03.01	RI-05.03	-FS
Available for	all ball bearing versions	all	all	wheel Ø 100–125 mm*	wheel Ø 150–200 mm*	wheel Ø 100–200 mm upon request

* Only for swivel castors without brake or swivel castor with "stop-top" brake upon request