

Light-duty wheels and castors

1



Selection tool

Light-duty wheels and castors

1



Series	TPA	VPA	POES
Tread / tyre	Thermoplastic rubber-elastomer (TPE)	Solid rubber	Elastic solid rubber "Blickle SoftMotion"
Tread and tyre hardness	85 Shore A	80 Shore A	55 Shore A
Non-marking	✓	✓	✓
Electrical conductivity	optional	optional	–
Wheel centre / rim	polypropylene	nylon	nylon
Wheel Ø	50–125 mm	50–150 mm	100–125 mm
Load capacity up to	125 kg	130 kg	150 kg
Rolling resistance	■ ■ ■ ■ ■	■ ■ ■ ■ ■	■ ■ ■ ■ ■
Smooth operation and floor preservation	■ ■ ■ ■ ■	■ ■ ■ ■ ■	■ ■ ■ ■ ■
Non-staining	tread contains oil; alternative: VPA, POES, PATH	✓	✓
For a description of the wheel, refer to	page 122	page 127	page 133
For information about swivel and fixed castors, refer to	page 123–126	page 128–132	page 134–135

■ ■ ■ ■ ■ excellent
 ■ ■ ■ ■ ■ very good
 ■ ■ ■ ■ ■ good
 ■ ■ ■ ■ ■ satisfactory
 ■ ■ ■ ■ ■ adequate
 ✓ yes – no



PATH	VSTH	POA
Thermoplastic polyurethane (TPU)	Polyurethane-elastomer Blickle Extrathane®	Nylon
94 Shore A	92 Shore A	70 Shore D
✓	✓	✓
optional	–	–
nylon	steel	nylon
50–125 mm	35–50 mm	35–150 mm
250 kg	150 kg	280 kg
■ ■ ■ ■ ■ □	■ ■ ■ ■ ■ □	■ ■ ■ ■ ■ ■
■ ■ ■ ■ □ □	■ ■ ■ □ □ □	■ ■ □ □ □ □
✓	✓	✓
page 136	page 286	page 143
page 137–140	page 141–142	page 144–147

TPA series

**Wheels with thermoplastic rubber tread,
with polypropylene wheel centre**



50–125 kg

Tread and tyre hardness

85 Shore A

Smooth operation / floor preservation

good

Rolling resistance

very good

Wear resistance

satisfactory

1

Tread:

- high-quality thermoplastic rubber-elastomer (TPE), hardness 85 Shore A
- low rolling and swivel resistance
- colour grey, non-marking
- chemically-bonded inseparable connection with the wheel centre

Wheel centre:

- high-quality polypropylene, impact resistant
- colour silver grey ("ELS" version colour black)

Other features:

- KF version: with synthetic thread guard, large
- very high chemical resistance to many aggressive substances
- operating temperature: -20 °C to +60 °C, reduced load capacity over +30 °C
- tread contains oil, may stain sensitive surfaces. alternatives: Series VPA, POES, PATH

Additional details:

- wheel series: page 60
- tread: page 52
- bearing types: page 84–85
- chemical resistance: page 51

Wheels	Wheel Ø	Wheel width	Load capacity	Bearing type	Axle bore Ø	Hub length
	(D) [mm]	(T2) [mm]	[kg]		(d) [mm]	(T1) [mm]
TPA 50/8G	50	19	50	plain bore	8	22
TPA 50/6KF	50	19	50	ball bearing (C)	6	23
TPA 75/8G	75	25	75	plain bore	8	29.5
TPA 75/6KF	75	25	75	ball bearing (C)	6	31
TPA 80/12G	80	32	100	plain bore	12	35
TPA 80/8KF	80	32	100	ball bearing (C)	8	36
TPA 100/8G	100	25	90	plain bore	8	29.5
TPA 101/12G	100	32	110	plain bore	12	35
TPA 101/8KF	100	32	110	ball bearing (C)	8	36
TPA 126/12G	125	32	125	plain bore	12	35
TPA 126/8KF	125	32	125	ball bearing (C)	8	36

For other dimensions, see page 186

Versions / options



	plain bore version	electrically conductive version, non-marking grey	large thread guard with additional ball bearing seals
Technical description page		50	85
Product code suffix		-ELS	-KFD
Available for		all*	all ball bearing versions

* Wheel load capacity of electrically conductive version reduced by 35%

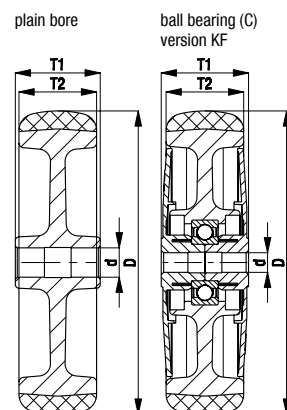

LRA-TPA, BRA-TPA, LKRA-TPA, BKRA-TPA series

Light duty castors with bolt hole,
wheel with thermoplastic
rubber tread

50–120 kg



- Bracket:** LRA/BRA, LKRA/BKRA series
- pressed steel, zinc-plated, blue-passivated, Cr6-free
- Swivel bracket:**
- double ball bearing in the swivel head
 - strong central kingpin
 - minimum swivel head play and smooth rolling characteristic and increased service life due to the special dynamic Blickle riveting process
 - synthetic "stop-fix" brake lever for series LRA, steel brake lever for series LKRA

- Wheel:** TPA series
- tread: high-quality thermoplastic rubber-elastomer (TPE), hardness 85 Shore A, colour grey, non-marking, oil containing
 - wheel centre: high-quality polypropylene, impact resistant, colour silver grey ("ELS" version colour black)

- Additional details:**
- bracket series: page 86
 - brakes: page 112–113
 - wheel series: page 122
 - bearing types: page 84–85

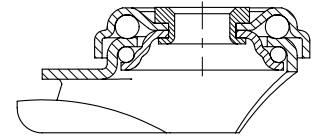

Swivel castors	Fixed castors	Swivel castors with "stop-fix" brake	Wheel Ø [mm]	Wheel width [mm]	Load capacity [kg]	Bearing type	Total height [mm]	Plate Ø [mm]	Bolt hole Ø [mm]	Offset swivel castor [mm]
LRA-TPA 50G	BRA-TPA 50G	LRA-TPA 50G-FI *	50	19	50	plain bore	69	43	11	23
LRA-TPA 50KF	BRA-TPA 50KF	LRA-TPA 50KF-FI *	50	19	50	ball bearing (C)	69	43	11	23
LRA-TPA 75G	BRA-TPA 75G	LRA-TPA 75G-FI *	75	25	75	plain bore	98	43	11	29
LRA-TPA 75KF	BRA-TPA 75KF	LRA-TPA 75KF-FI *	75	25	75	ball bearing (C)	98	43	11	29
LKRA-TPA 80G	BKRA-TPA 80G	LKRA-TPA 80G-FI	80	32	100	plain bore	108	57	13	40
LKRA-TPA 80G-11		LKRA-TPA 80G-11-FI	80	32	100	plain bore	108	57	11	40
LKRA-TPA 80KF	BKRA-TPA 80KF	LKRA-TPA 80KF-FI	80	32	100	ball bearing (C)	108	57	13	40
LKRA-TPA 80KF-11		LKRA-TPA 80KF-11-FI	80	32	100	ball bearing (C)	108	57	11	40
LRA-TPA 100G		LRA-TPA 100G-FI *	100	25	70	plain bore	121	43	11	33
LKRA-TPA 101G	BKRA-TPA 101G	LKRA-TPA 101G-FI	100	32	110	plain bore	133	57	13	40
LKRA-TPA 101G-11		LKRA-TPA 101G-11-FI	100	32	110	plain bore	133	57	11	40
LKRA-TPA 101KF	BKRA-TPA 101KF	LKRA-TPA 101KF-FI	100	32	110	ball bearing (C)	133	57	13	40
LKRA-TPA 101KF-11		LKRA-TPA 101KF-11-FI	100	32	110	ball bearing (C)	133	57	11	40
LKRA-TPA 126G	BKRA-TPA 126G	LKRA-TPA 126G-FI	125	32	120	plain bore	158	57	13	40
LKRA-TPA 126G-11		LKRA-TPA 126G-11-FI	125	32	120	plain bore	158	57	11	40
LKRA-TPA 126KF	BKRA-TPA 126KF	LKRA-TPA 126KF-FI	125	32	120	ball bearing (C)	158	57	13	40
LKRA-TPA 126KF-11		LKRA-TPA 126KF-11-FI	125	32	120	ball bearing (C)	158	57	11	40

* Synthetic brake lever, see image below

For stainless steel versions, see page 390

Versions / options**



	plain bore version	with synthetic brake lever	electrically conductive version, non-marking grey	with threaded pin M10 x 30 M12 x 30	with plug-in pin Ø 11 x 30.5	with synthetic expander fitting	with metal expander fitting
Technical description page			50	104	105	105	105
Product code suffix			-ELS	-GS10 / -GS12	-ES	see page 148	see page 148
Available for		series LRA...-FI as standard	all***	-GS10: series LRA -GS12: series LKRA	series LRA swivel castors****	swivel castors with bolt hole Ø 11 mm (except ELS)	swivel castors with bolt hole Ø 11 mm

** Other versions / options: buffers AG / ARG series see page 148 (page 116 for technical information)

*** Wheel load capacity of electrically conductive version reduced by 35%

**** Synthetic castor socket for round tubes see page 148

LPA-TPA, BPA-TPA, LKPA-TPA, BKPA-TPA series

Light duty castors with top plate,
wheel with thermoplastic
rubber tread



50–120 kg

Bracket: LPA/BPA, LKPA/BKPA series

- pressed steel, zinc-plated, blue-passivated, Cr6-free

Swivel bracket:

- double ball bearing in the swivel head
- strong central kingpin
- minimum swivel head play and smooth rolling characteristic and increased service life due to the special dynamic Blickle riveting process
- synthetic “stop-fix” brake lever for series LPA, steel brake lever for series LKPA

Wheel: TPA series

- tread: high-quality thermoplastic rubber-elastomer (TPE), hardness 85 Shore A, colour grey, non-marking, oil containing
- wheel centre: high-quality polypropylene, impact resistant, colour silver grey (“-ELS” version colour black)

Additional details:

- bracket series: page 86
- brakes: page 112–113
- wheel series: page 122
- bearing types: page 84–85

1

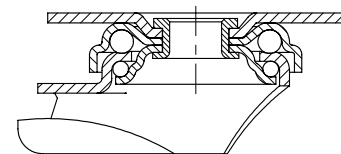

Swivel castors	Fixed castors	Swivel castors with “stop-fix” brake	Wheel Ø [mm]	Wheel width [mm]	Load capacity [kg]	Bearing type	Total height [mm]	Plate size [mm]	Bolt hole spacing [mm]	Bolt hole Ø [mm]	Offset swivel castor [mm]
LPA-TPA 50G	BPA-TPA 50G	LPA-TPA 50G-FI *	50	19	50	plain bore	71	60 x 60	38 x 38 / 48 x 48	6.2	23
LPA-TPA 50KF	BPA-TPA 50KF	LPA-TPA 50KF-FI *	50	19	50	ball bearing (C)	71	60 x 60	38 x 38 / 48 x 48	6.2	23
LPA-TPA 75G	BPA-TPA 75G	LPA-TPA 75G-FI *	75	25	75	plain bore	100	60 x 60	38 x 38 / 48 x 48	6.2	29
LPA-TPA 75KF	BPA-TPA 75KF	LPA-TPA 75KF-FI *	75	25	75	ball bearing (C)	100	60 x 60	38 x 38 / 48 x 48	6.2	29
LKPA-TPA 80G	BKPA-TPA 80G	LKPA-TPA 80G-FI	80	32	100	plain bore	111	90 x 66	75 x 45 / 61 x 51	8.5	40
LKPA-TPA 80KF	BKPA-TPA 80KF	LKPA-TPA 80KF-FI	80	32	100	ball bearing (C)	111	90 x 66	75 x 45 / 61 x 51	8.5	40
LPA-TPA 100G		LPA-TPA 100G-FI *	100	25	70	plain bore	123	60 x 60	38 x 38 / 48 x 48	6.2	33
LKPA-TPA 101G	BKPA-TPA 101G	LKPA-TPA 101G-FI	100	32	110	plain bore	136	90 x 66	75 x 45 / 61 x 51	8.5	40
LKPA-TPA 101KF	BKPA-TPA 101KF	LKPA-TPA 101KF-FI	100	32	110	ball bearing (C)	136	90 x 66	75 x 45 / 61 x 51	8.5	40
LKPA-TPA 126G	BKPA-TPA 126G	LKPA-TPA 126G-FI	125	32	120	plain bore	161	90 x 66	75 x 45 / 61 x 51	8.5	40
LKPA-TPA 126KF	BKPA-TPA 126KF	LKPA-TPA 126KF-FI	125	32	120	ball bearing (C)	161	90 x 66	75 x 45 / 61 x 51	8.5	40

* Synthetic brake lever, see image below

For stainless steel versions, see page 391

Versions / options



	plain bore version	with synthetic brake lever	electrically conductive version, non-marking grey
Technical description page			50
Product code suffix			-ELS
Available for		series LPA...-FI as standard	all**

** Wheel load capacity of electrically conductive version reduced by 35%

LMDA-TPA series

Twin wheel light duty castors with bolt hole, wheels with thermoplastic rubber tread

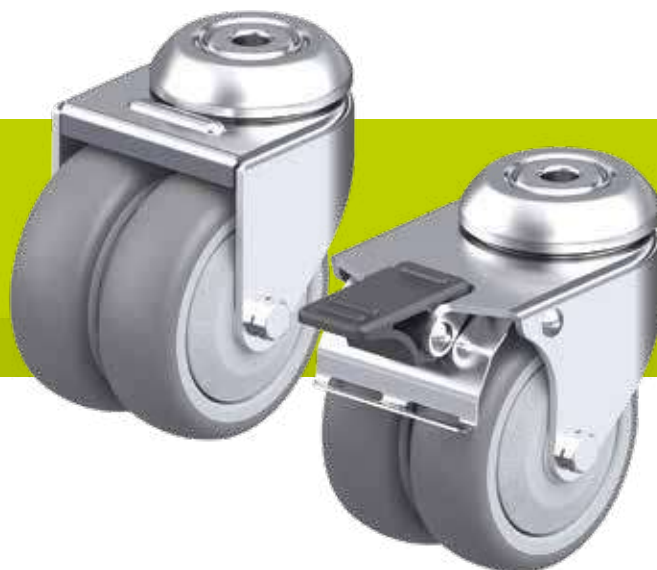

1

80–100 kg

Bracket: LMDA series

- pressed steel, zinc-plated, blue-passivated, Cr6-free
- double ball bearing in the swivel head
- pressed swivel head

Wheel: TPA series

- tread: high-quality thermoplastic rubber-elastomer (TPE), hardness 85 Shore A, colour grey, non-marking, oil containing
- wheel centre: high-quality polypropylene, impact resistant, colour silver grey ("ELS" version colour black)

Additional details:

- bracket series: page 86
- brakes: page 112–113
- wheel series: page 122
- bearing types: page 84–85

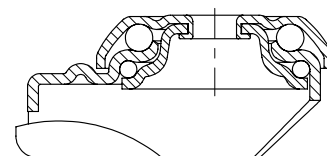

Swivel castors	Swivel castors with "stop-fix" brake	Wheel Ø [mm]	Wheel width [mm]	Load capacity [kg]	Bearing type	Total height [mm]	Plate Ø [mm]	Bolt hole Ø [mm]	Offset swivel castor [mm]
LMDA-TPA 50G	LMDA-TPA 50G-FI	50	2 x 19	80	plain bore	71	41	10.2	31
LMDA-TPA 50KF	LMDA-TPA 50KF-FI	50	2 x 19	80	ball bearing (C)	71	41	10.2	31
LMDA-TPA 75G	LMDA-TPA 75G-FI	75	2 x 25	100	plain bore	98	55	10.2	34
LMDA-TPA 75KF	LMDA-TPA 75KF-FI	75	2 x 25	100	ball bearing (C)	98	55	10.2	34

Versions / options



	plain bore version	electrically conductive version, non-marking grey
Technical description page		50
Product code suffix		-ELS
Available for		all*

* Wheel load capacity of electrically conductive version reduced by 35%

LDA-TPA series

Twin wheel light duty castors with top plate, wheels with thermoplastic rubber tread

80–100 kg

Bracket: LDA series

- pressed steel, zinc-plated, blue-passivated, Cr6-free
- double ball bearing in the swivel head
- pressed swivel head

Wheel: TPA series

- tread: high-quality thermoplastic rubber-elastomer (TPE), hardness 85 Shore A, colour grey, non-marking, oil containing
- wheel centre: high-quality polypropylene, impact resistant, colour silver grey ("ELS" version colour black)

Additional details:

- bracket series: page 86
- brakes: page 112–113
- wheel series: page 122
- bearing types: page 84–85

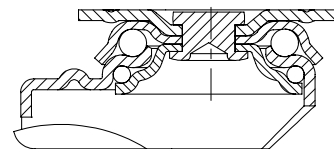
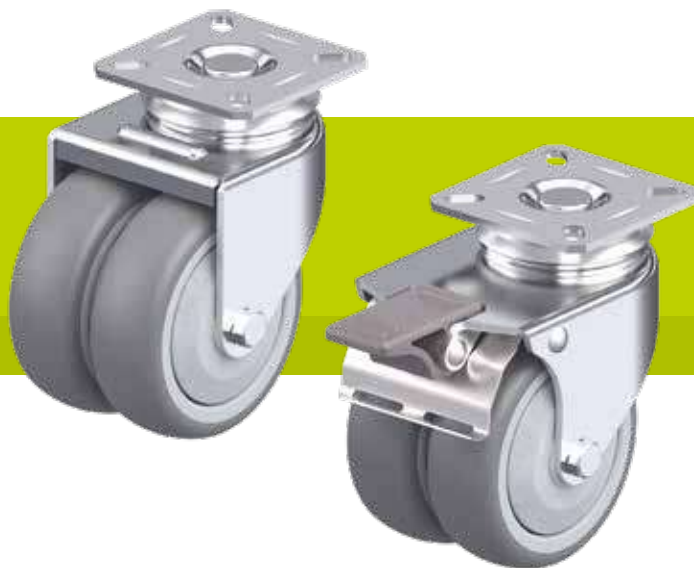

Swivel castors	Swivel castors with "stop-fix" brake	Wheel Ø [mm]	Wheel width [mm]	Load capacity [kg]	Bearing type	Total height [mm]	Plate size [mm]	Bolt hole spacing [mm]	Bolt hole Ø [mm]	Offset swivel castor [mm]
LDA-TPA 50G	LDA-TPA 50G-FI	50	2 x 19	80	plain bore	71	60 x 60	38 x 38 / 48 x 48	6.2	31
LDA-TPA 50KF	LDA-TPA 50KF-FI	50	2 x 19	80	ball bearing (C)	71	60 x 60	38 x 38 / 48 x 48	6.2	31
LDA-TPA 75G	LDA-TPA 75G-FI	75	2 x 25	100	plain bore	101	60 x 60	40 x 40 / 46 x 46	6.2	34
LDA-TPA 75KF	LDA-TPA 75KF-FI	75	2 x 25	100	ball bearing (C)	101	60 x 60	40 x 40 / 46 x 46	6.2	34

Versions / options



	plain bore version	electrically conductive version, non-marking grey
Technical description page		50
Product code suffix		-ELS
Available for		all*

* Wheel load capacity of electrically conductive version reduced by 35%

VPA series

Wheels with solid rubber tyre,
with synthetic rim



1

40–130 kg

Tread and tyre hardness
 80 Shore A

Smooth operation / floor preservation
 very good

Rolling resistance
 good

Wear resistance
 sufficient

- Tyre:**
- high-quality solid rubber, hardness 80 Shore A
 - very good operational comfort
 - very good floor preservation, low-noise operation
 - colour grey, non-marking, non-staining (electrically conductive version “-EL” colour black, marking)

- Rim:**
- high-quality nylon 6 or polypropylene in the version “-EL”, impact resistant
 - colour black

- Other features:**
- high chemical resistance to many aggressive substances, except oils
 - operating temperature: -20 °C to +60 °C, reduced load capacity over +30 °C

Additional details:

- wheel series: page 60
- tread: page 52
- bearing types: page 84–85
- chemical resistance: page 51

Wheels	Wheel Ø (D) [mm]	Tyre width (T2) [mm]	Load capacity [kg]	Bearing type	Axle bore Ø (d) [mm]	Hub length (T1) [mm]
VPA 50/6G	50	18	40	plain bore	6	22
VPA 50/8G	50	18	40	plain bore	8	22
VPA 50/6K	50	18	40	ball bearing	6	22.5
VPA 75/8G	75	25	60	plain bore	8	29.5
VPA 75/6K	75	25	60	ball bearing	6	30
VPA 80/12G	80	25	80	plain bore	12	35
VPA 80/8K	80	25	80	ball bearing	8	35
VPA 100/8G	100	25	90	plain bore	8	29.5
VPA 100/12G	100	25	90	plain bore	12	29.5
VPA 100/6K	100	25	90	ball bearing	6	30
VPA 101/12G	100	32	110	plain bore	12	35
VPA 101/8K	100	32	110	ball bearing	8	35
VPA 125/12G	125	25	100	plain bore	12	35
VPA 125/8K	125	25	100	ball bearing	8	35
VPA 126/12G	125	32	125	plain bore	12	35
VPA 126/8K	125	32	125	ball bearing	8	35
VPA 150/12G	150	30	130	plain bore	12	35
VPA 150/8K	150	30	130	ball bearing	8	35

Versions / options



	plain bore version	electrically conductive version, black tyre
Technical description page		50
Product code suffix		-EL
Available for		all ball bearing versions*

* Wheel load capacity of electrically conductive version reduced by 25%

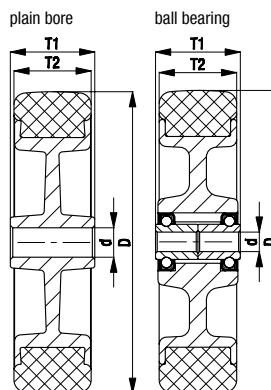

LRA, BRA, LKRA, BKRA-VPA series (wheel Ø 50–100 mm)

Light duty castors with bolt hole, wheel with solid rubber tyres



40–110 kg

- Bracket:** LRA/BRA, LKRA/BKRA series
- pressed steel, zinc-plated, blue-passivated, Cr6-free
- Swivel bracket:**
- double ball bearing in the swivel head
 - strong central kingpin
 - minimum swivel head play and smooth rolling characteristic and increased service life due to the special dynamic Blickle riveting process
 - synthetic "stop-fix" brake lever for series LRA, steel brake lever for series LKRA

- Wheel:** VPA series
- tyre: high-quality solid rubber, hardness 80 Shore A, colour grey, non-marking, non-staining
 - rim: high-quality nylon 6 or polypropylene in the electrically conductive version "-EL", impact resistant, colour black

- Additional details:**
- bracket series: page 86
 - brakes: page 112–113
 - wheel series: page 127
 - bearing types: page 84–85

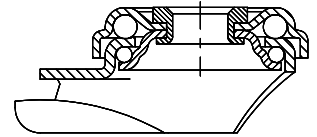

Swivel castors	Fixed castors	Swivel castors with "stop-fix" brake	Wheel Ø [mm]	Tyre width [mm]	Load capacity [kg]	Bearing type	Total height [mm]	Plate Ø [mm]	Bolt hole Ø [mm]	Offset swivel castor [mm]
LRA-VPA 50G	BRA-VPA 50G	LRA-VPA 50G-FI *	50	18	40	plain bore	69	43	11	23
LRA-VPA 50K	BRA-VPA 50K	LRA-VPA 50K-FI *	50	18	40	ball bearing	69	43	11	23
LRA-VPA 75G	BRA-VPA 75G	LRA-VPA 75G-FI *	75	25	60	plain bore	98	43	11	29
LRA-VPA 75K	BRA-VPA 75K	LRA-VPA 75K-FI *	75	25	60	ball bearing	98	43	11	29
LKRA-VPA 80G	BKRA-VPA 80G	LKRA-VPA 80G-FI	80	25	80	plain bore	108	57	13	40
LKRA-VPA 80G-11		LKRA-VPA 80G-11-FI	80	25	80	plain bore	108	57	11	40
LKRA-VPA 80K	BKRA-VPA 80K	LKRA-VPA 80K-FI	80	25	80	ball bearing	108	57	13	40
LKRA-VPA 80K-11		LKRA-VPA 80K-11-FI	80	25	80	ball bearing	108	57	11	40
LRA-VPA 100G		LRA-VPA 100G-FI *	100	25	70	plain bore	121	43	11	33
LRA-VPA 100K		LRA-VPA 100K-FI *	100	25	70	ball bearing	121	43	11	33
LKRA-VPA 101G	BKRA-VPA 101G	LKRA-VPA 101G-FI	100	32	110	plain bore	133	57	13	40
LKRA-VPA 101G-11		LKRA-VPA 101G-11-FI	100	32	110	plain bore	133	57	11	40
LKRA-VPA 101K	BKRA-VPA 101K	LKRA-VPA 101K-FI	100	32	110	ball bearing	133	57	13	40
LKRA-VPA 101K-11		LKRA-VPA 101K-11-FI	100	32	110	ball bearing	133	57	11	40

* Synthetic brake lever, see image below

For other wheel Ø, see next page, For stainless steel versions, see page 392

Versions / options**



	with synthetic brake lever	electrically conductive version, black tyre	with threaded pin M10 x 30 M12 x 30	with plug-in pin Ø 11 x 30.5	with synthetic expander fitting	with metal expander fitting
Technical description page		50	104	105	105	105
Product code suffix		-EL	-GS10 / -GS12	-ES	see page 148	see page 148
Available for	series LRA...-FI as standard	all ball bearing versions***	-GS10: series LRA -GS12: series LKRA	series LRA swivel castors****	swivel castors with bolt hole Ø 11 mm (except EL)	swivel castors with bolt hole Ø 11 mm

** Other versions / options: 1. buffers AG / ARG series see page 148 (page 116 for technical information) 2. pressed steel thread guard, zinc-plated (-FA), available for all with exception of ...50K (page 116 for technical information)

*** Wheel load capacity of electrically conductive version reduced by 25%

**** Synthetic castor socket for round tubes see page 148

LKRA-VPA, BKRA-VPA series (wheel Ø 125–150 mm)

**Light duty castors
with bolt hole,
wheel with solid rubber tyres**



1

100–120 kg

Bracket: LKRA/BKRA series

- pressed steel, zinc-plated, blue-passivated, Cr6-free

Swivel bracket:

- double ball bearing in the swivel head
- strong central kingpin
- minimum swivel head play and smooth rolling characteristic and increased service life due to the special dynamic Blickle riveting process

Wheel: VPA series

- tyre: high-quality solid rubber, hardness 80 Shore A, colour grey, non-marking, non-staining
- rim: high-quality nylon 6 or polypropylene in the electrically conductive version “-EL”, impact resistant, colour black

Additional details:

- bracket series: page 86
- brakes: page 112–113
- wheel series: page 127
- bearing types: page 84–85

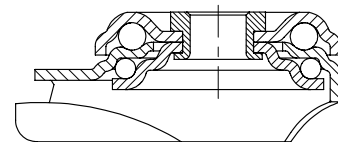

Swivel castors	Fixed castors	Swivel castors with “stop-fix” brake	Wheel Ø [mm]	Tyre width [mm]	Load capacity [kg]	Bearing type	Total height [mm]	Plate Ø [mm]	Bolt hole Ø [mm]	Offset swivel castor [mm]
LKRA-VPA 125G	BKRA-VPA 125G	LKRA-VPA 125G-FI	125	25	100	plain bore	158	57	13	40
LKRA-VPA 125G-11		LKRA-VPA 125G-11-FI	125	25	100	plain bore	158	57	11	40
LKRA-VPA 125K	BKRA-VPA 125K	LKRA-VPA 125K-FI	125	25	100	ball bearing	158	57	13	40
LKRA-VPA 125K-11		LKRA-VPA 125K-11-FI	125	25	100	ball bearing	158	57	11	40
LKRA-VPA 126G	BKRA-VPA 126G	LKRA-VPA 126G-FI	125	32	120	plain bore	158	57	13	40
LKRA-VPA 126G-11		LKRA-VPA 126G-11-FI	125	32	120	plain bore	158	57	11	40
LKRA-VPA 126K	BKRA-VPA 126K	LKRA-VPA 126K-FI	125	32	120	ball bearing	158	57	13	40
LKRA-VPA 126K-11		LKRA-VPA 126K-11-FI	125	32	120	ball bearing	158	57	11	40
LKRA-VPA 150G	BKRA-VPA 150G	LKRA-VPA 150G-FI	150	30	110	plain bore	182	57	13	40
LKRA-VPA 150G-11		LKRA-VPA 150G-11-FI	150	30	110	plain bore	182	57	11	40
LKRA-VPA 150K	BKRA-VPA 150K	LKRA-VPA 150K-FI	150	30	110	ball bearing	182	57	13	40
LKRA-VPA 150K-11		LKRA-VPA 150K-11-FI	150	30	110	ball bearing	182	57	11	40

For stainless steel versions, see page 392

Versions / options



	electrically conductive version, black tyre	with thread guard, pressed steel, zinc-plated	with threaded pin M12 x 30	with synthetic expander fitting	with metal expander fitting	buffers
Technical description page	50	116	104	105	105	116
Product code suffix	-EL	-FA	-GS12	see page 148	see page 148	AG / ARG series
Available for	all ball bearing versions*	all	swivel castors with bolt hole Ø 13 mm	swivel castors with bolt hole Ø 11 mm (except EL)	swivel castors with bolt hole Ø 11 mm	see page 148

* Wheel load capacity of electrically conductive version reduced by 25%

LPA-VPA, BPA-VPA, LKPA-VPA, BKPA-VPA series

Light duty castors with top plate, wheel with solid rubber tyres

40–120 kg



Bracket: LPA/BPA, LKPA/BKPA series

- pressed steel, zinc-plated, blue-passivated, Cr6-free

Swivel bracket:

- double ball bearing in the swivel head
- strong central kingpin
- minimum swivel head play and smooth rolling characteristic and increased service life due to the special dynamic Blickle riveting process
- synthetic “stop-fix” brake lever for series LPA, steel brake lever for series LKPA

Wheel: VPA series

- tyre: high-quality solid rubber, hardness 80 Shore A, colour grey, non-marking, non-staining
- rim: high-quality nylon 6 or polypropylene in the electrically conductive version “-EL”, impact resistant, colour black

Additional details:

- bracket series: page 86
- brakes: page 112–113
- wheel series: page 127
- bearing types: page 84–85

1

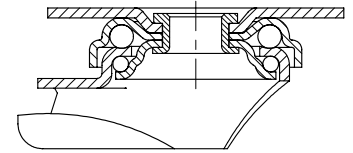

Swivel castors	Fixed castors	Swivel castors with “stop-fix” brake	Wheel Ø [mm]	Tyre width [mm]	Load capacity [kg]	Bearing type	Total height [mm]	Plate size [mm]	Bolt hole spacing [mm]	Bolt hole Ø [mm]	Offset swivel castor [mm]
LPA-VPA 50G	BPA-VPA 50G	LPA-VPA 50G-FI *	50	18	40	plain bore	71	60 x 60	38 x 38 / 48 x 48	6.2	23
LPA-VPA 50K	BPA-VPA 50K	LPA-VPA 50K-FI *	50	18	40	ball bearing	71	60 x 60	38 x 38 / 48 x 48	6.2	23
LPA-VPA 75G	BPA-VPA 75G	LPA-VPA 75G-FI *	75	25	60	plain bore	100	60 x 60	38 x 38 / 48 x 48	6.2	29
LPA-VPA 75K	BPA-VPA 75K	LPA-VPA 75K-FI *	75	25	60	ball bearing	100	60 x 60	38 x 38 / 48 x 48	6.2	29
LKPA-VPA 80G	BKPA-VPA 80G	LKPA-VPA 80G-FI	80	25	80	plain bore	111	90 x 66	75 x 45 / 61 x 51	8.5	40
LKPA-VPA 80K	BKPA-VPA 80K	LKPA-VPA 80K-FI	80	25	80	ball bearing	111	90 x 66	75 x 45 / 61 x 51	8.5	40
LPA-VPA 100G		LPA-VPA 100G-FI *	100	25	70	plain bore	123	60 x 60	38 x 38 / 48 x 48	6.2	33
LPA-VPA 100K		LPA-VPA 100K-FI *	100	25	70	ball bearing	123	60 x 60	38 x 38 / 48 x 48	6.2	33
LKPA-VPA 101G	BKPA-VPA 101G	LKPA-VPA 101G-FI	100	32	110	plain bore	136	90 x 66	75 x 45 / 61 x 51	8.5	40
LKPA-VPA 101K	BKPA-VPA 101K	LKPA-VPA 101K-FI	100	32	110	ball bearing	136	90 x 66	75 x 45 / 61 x 51	8.5	40
LKPA-VPA 125G	BKPA-VPA 125G	LKPA-VPA 125G-FI	125	25	100	plain bore	161	90 x 66	75 x 45 / 61 x 51	8.5	40
LKPA-VPA 125K	BKPA-VPA 125K	LKPA-VPA 125K-FI	125	25	100	ball bearing	161	90 x 66	75 x 45 / 61 x 51	8.5	40
LKPA-VPA 126G	BKPA-VPA 126G	LKPA-VPA 126G-FI	125	32	120	plain bore	161	90 x 66	75 x 45 / 61 x 51	8.5	40
LKPA-VPA 126K	BKPA-VPA 126K	LKPA-VPA 126K-FI	125	32	120	ball bearing	161	90 x 66	75 x 45 / 61 x 51	8.5	40
LKPA-VPA 150G	BKPA-VPA 150G	LKPA-VPA 150G-FI	150	30	110	plain bore	185	90 x 66	75 x 45 / 61 x 51	8.5	40
LKPA-VPA 150K	BKPA-VPA 150K	LKPA-VPA 150K-FI	150	30	110	ball bearing	185	90 x 66	75 x 45 / 61 x 51	8.5	40

* Synthetic brake lever, see image below

For stainless steel versions, see page 393

Versions / options



	with synthetic brake lever	electrically conductive version, black tyre	with thread guard, pressed steel, zinc-plated
Technical description page		50	116
Product code suffix		-EL	-FA
Available for	series LPA...-FI as standard	all ball bearing versions**	all with exception of ...50K

** Wheel load capacity of electrically conductive version reduced by 25%

LMDA-VPA series

Twin wheel light duty castors with bolt hole, wheels with solid rubber tyres



80–100 kg

Bracket: LMDA series

- pressed steel, zinc-plated, blue-passivated, Cr6-free
- double ball bearing in the swivel head
- pressed swivel head

Wheel: VPA series

- tyre: high-quality solid rubber, hardness 80 Shore A, colour grey, non-marking, non-staining
- rim: high-quality nylon 6 or polypropylene in the electrically conductive version “-EL”, impact resistant, colour black

Additional details:

- bracket series: page 86
- brakes: page 112–113
- wheel series: page 127
- bearing types: page 84–85

1

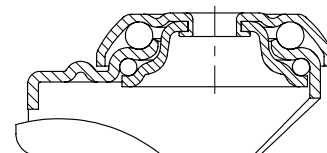

Swivel castors	Swivel castors with “stop-fix” brake	Wheel Ø [mm]	Wheel width [mm]	Load capacity [kg]	Bearing type	Total height [mm]	Plate Ø [mm]	Bolt hole Ø [mm]	Offset swivel castor [mm]
LMDA-VPA 50G	LMDA-VPA 50G-FI	50	2 x 18	80	plain bore	71	41	10.2	31
LMDA-VPA 50K	LMDA-VPA 50K-FI	50	2 x 18	80	ball bearing	71	41	10.2	31
LMDA-VPA 75G	LMDA-VPA 75G-FI	75	2 x 25	100	plain bore	98	55	10.2	34
LMDA-VPA 75K	LMDA-VPA 75K-FI	75	2 x 25	100	ball bearing	98	55	10.2	34

Versions / options



Technically	electrically conductive version, black tyre
Technical description page	50
Product code suffix	-EL
Available for	all ball bearing versions*

* Wheel load capacity of electrically conductive version reduced by 25%

LDA-VPA series

Twin wheel light duty castors with top plate, wheels with solid rubber tyres

80–100 kg

Bracket: LDA series

- pressed steel, zinc-plated, blue-passivated, Cr6-free
- double ball bearing in the swivel head
- pressed swivel head

Wheel: VPA series

- tyre: high-quality solid rubber, hardness 80 Shore A, colour grey, non-marking, non-staining
- rim: high-quality nylon 6 or polypropylene in the electrically conductive version "-EL", impact resistant, colour black

Additional details:

- bracket series: page 86
- brakes: page 112–113
- wheel series: page 127
- bearing types: page 84–85

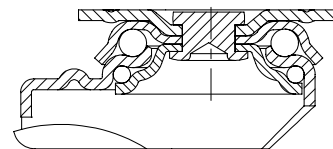

Swivel castors	Swivel castors with "stop-fix" brake	Wheel Ø [mm]	Tyre width [mm]	Load capacity [kg]	Bearing type	Total height [mm]	Plate size [mm]	Bolt hole spacing [mm]	Bolt hole Ø [mm]	Offset swivel castor [mm]
LDA-VPA 50G	LDA-VPA 50G-FI	50	2 x 18	80	plain bore	71	60 x 60	38 x 38 / 48 x 48	6.2	31
LDA-VPA 50K	LDA-VPA 50K-FI	50	2 x 18	80	ball bearing	71	60 x 60	38 x 38 / 48 x 48	6.2	31
LDA-VPA 75G	LDA-VPA 75G-FI	75	2 x 25	100	plain bore	101	60 x 60	40 x 40 / 46 x 46	6.2	34
LDA-VPA 75K	LDA-VPA 75K-FI	75	2 x 25	100	ball bearing	101	60 x 60	40 x 40 / 46 x 46	6.2	34

Versions / options



	electrically conductive version, black tyre
Technical description page	50
Product code suffix	-EL
Available for	all ball bearing versions*

* Wheel load capacity of electrically conductive version reduced by 25%

POES series

Wheels with “Blickle SoftMotion” soft rubber tyres, with nylon wheel centre

120–150 kg

Tread and tyre hardness

55 Shore A

Smooth operation / floor preservation

excellent

Rolling resistance

very good

Wear resistance

good



1

Tyre:

- high-quality elastic solid rubber “Blickle SoftMotion”, hardness 55 Shore A
- maximum operational comfort
- excellent floor preservation, particularly quiet operation
- low rolling resistance
- colour grey, non-marking
- vulcanised onto the wheel centre

Wheel centre:

- high-quality nylon 6, impact resistant
- colour black

Other features:

- KF version: with synthetic thread guard, large
- high chemical resistance to many aggressive substances, except oils
- operating temperature: -20 °C to +80 °C, temporarily up to +100 °C, reduced load capacity over +35 °C

Additional details:

- wheel series: page 60
- tread: page 53
- bearing types: page 84–85
- chemical resistance: page 51

Wheels	Wheel Ø	Wheel width	Load capacity	Bearing type	Axle bore Ø	Hub length
	(D) [mm]	(T2) [mm]	[kg]		(d) [mm]	(T1) [mm]
POES 102/8KF-SG	100	32	120	ball bearing (C)	8	36
POES 127/8KF-SG	125	32	150	ball bearing (C)	8	36

For other dimensions, see page 209

Versions / options



	large thread guard with additional ball bearing seals	with stainless steel ball bearing and thread guard
Technical description page	85	85
Product code suffix	-KFD	-XKF
Available for	upon request	all

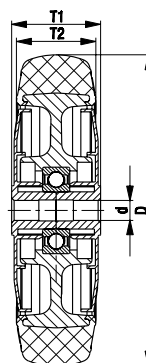

LKRA-POES, BKRA-POES series

Light duty castors with bolt hole,
wheel with soft rubber tyres
"Blickle SoftMotion"



120 kg

Bracket: LKRA/BKRA series

- pressed steel, zinc-plated, blue-passivated, Cr6-free

Swivel bracket:

- double ball bearing in the swivel head
- strong central kingpin
- minimum swivel head play and smooth rolling characteristic and increased service life due to the special dynamic Blickle riveting process
- steel "stop-fix" brake lever

Wheel: POES series

- tyre: high-quality elastic solid rubber "Blickle SoftMotion", hardness 55 Shore A, colour grey, non-marking
- wheel centre: high-quality nylon 6, impact resistant, colour black

Additional details:

- bracket series: page 86
- brakes: page 112–113
- wheel series: page 133
- bearing types: page 84–85

1

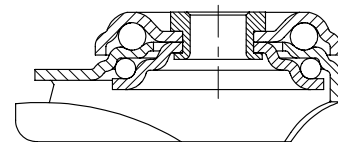

Swivel castors	Fixed castors	Swivel castors with "stop-fix" brake	Wheel Ø [mm]	Wheel width [mm]	Load capacity [kg]	Bearing type	Total height [mm]	Plate Ø [mm]	Bolt hole Ø [mm]	Offset swivel castor [mm]
LKRA-POES 102KF-SG	BKRA-POES 102KF-SG	LKRA-POES 102KF-FI-SG	100	32	120	ball bearing (C)	133	57	13	40
LKRA-POES 102KF-11-SG		LKRA-POES 102KF-11-FI-SG	100	32	120	ball bearing (C)	133	57	11	40
LKRA-POES 127KF-SG	BKRA-POES 127KF-SG	LKRA-POES 127KF-FI-SG	125	32	120	ball bearing (C)	158	57	13	40
LKRA-POES 127KF-11-SG		LKRA-POES 127KF-11-FI-SG	125	32	120	ball bearing (C)	158	57	11	40

Versions / options



	with threaded pin M12 x 30	with synthetic expander fitting	with metal expander fitting
Technical description page	104	105	105
Product code suffix	-GS12	see page 148	see page 148
Available for	swivel castors with bolt hole Ø 13 mm	swivel castors with bolt hole Ø 11 mm	swivel castors with bolt hole Ø 11 mm

LKPA-POES, BKPA-POES series

Light duty castors with top plate,
wheel with soft rubber tyres
"Blickle SoftMotion"



120 kg

Bracket: LKPA/BKPA series

- pressed steel, zinc-plated, blue-passivated, Cr6-free

Swivel bracket:

- double ball bearing in the swivel head
- minimum swivel head play and smooth rolling characteristic and increased service life due to the special dynamic Blickle riveting process
- steel "stop-fix" brake lever

Wheel: POES series

- tyre: high-quality elastic solid rubber "Blickle SoftMotion", hardness 55 Shore A, colour grey, non-marking
- wheel centre: high-quality nylon 6, impact resistant, colour black

Additional details:

- bracket series: page 86
- brakes: page 112–113
- wheel series: page 133
- bearing types: page 84–85

1

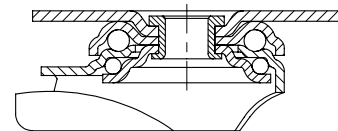

Swivel castors	Fixed castors	Swivel castors with "stop-fix" brake	Wheel Ø [mm]	Wheel width [mm]	Load capacity [kg]	Bearing type	Total height [mm]	Plate size [mm]	Bolt hole spacing [mm]	Bolt hole Ø [mm]	Offset swivel castor [mm]
LKPA-POES 102KF-SG	BKPA-POES 102KF-SG	LKPA-POES 102KF-FI-SG	100	32	120	ball bearing (C)	136	90 x 66	75 x 45 / 61 x 51	8.5	40
LKPA-POES 127KF-SG	BKPA-POES 127KF-SG	LKPA-POES 127KF-FI-SG	125	32	120	ball bearing (C)	161	90 x 66	75 x 45 / 61 x 51	8.5	40

PATH series

Wheels with thermoplastic polyurethane tread, with nylon wheel centre



75–250 kg

Tread and tyre hardness



94 Shore A

Smooth operation / floor preservation



good

Rolling resistance



very good

Wear resistance



very good

1

Tread:

- high-quality thermoplastic polyurethane (TPU), hardness 94 Shore A
- low rolling and swivel resistance
- high abrasion resistance
- colour dark grey, non-marking, non-staining
- chemically-bonded inseparable connection with the wheel centre

Wheel centre:

- high-quality nylon 6, impact resistant
- colour silver grey

Other features:

- KF version: with synthetic thread guard, large
- very high chemical resistance to many aggressive substances
- operating temperature: -20 °C to +70 °C, temporarily up to +90 °C, reduced load capacity over +35 °C

Additional details:

- wheel series: page 61
- tread: page 55
- bearing types: page 84–85
- chemical resistance: page 51

Wheels	Wheel Ø	Wheel width	Load capacity	Bearing type	Axle bore Ø	Hub length
	(D) [mm]	(T2) [mm]	[kg]		(d) [mm]	(T1) [mm]
PATH 50/8G	50	19	75	plain bore	8	22
PATH 50/6KF	50	19	75	ball bearing (C)	6	23
PATH 75/8G	75	25	100	plain bore	8	29.5
PATH 75/6KF	75	25	100	ball bearing (C)	6	31
PATH 80/12G	80	32	150	plain bore	12	35
PATH 80/8KF	80	32	150	ball bearing (C)	8	36
PATH 101/12G	100	32	200	plain bore	12	35
PATH 101/8KF	100	32	200	ball bearing (C)	8	36
PATH 126/12G	125	32	250	plain bore	12	35
PATH 126/8KF	125	32	250	ball bearing (C)	8	36

For other dimensions, see page 258

Versions / options



plain bore version

electrically conductive version, non-marking grey

large thread guard with additional ball bearing seals

Technical description page

50

85

Product code suffix

-ELS

-KFD

Available for

all ball bearing versions*

ball bearing versions

* Wheel load capacity of electrically conductive version reduced by 35%

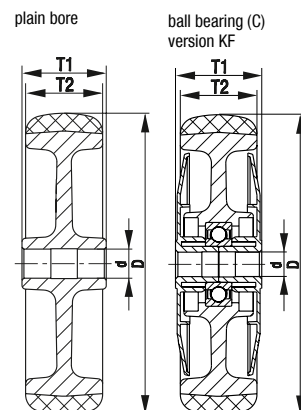

LRA-PATH, BRA-PATH, LKRA-PATH, BKRA-PATH series

Light duty castors with bolt hole,
wheel with thermoplastic
polyurethane tread

75–120 kg



- Bracket:** LRA/BRA, LKRA/BKRA series
- pressed steel, zinc-plated, blue-passivated, Cr6-free
- Swivel bracket:**
- double ball bearing in the swivel head
 - strong central kingpin
 - minimum swivel head play and smooth rolling characteristic and increased service life due to the special dynamic Blickle riveting process
 - synthetic “stop-fix” brake lever for series LRA, steel brake lever for series LKRA

- Wheel:** PATH series
- tread: high-quality thermoplastic polyurethane (TPU), hardness 94 Shore A, colour dark grey, non-marking, non-staining
 - wheel centre: high-quality nylon 6, impact resistant, colour silver grey

- Additional details:**
- bracket series: page 86
 - brakes: page 112–113
 - wheel series: page 136
 - bearing types: page 84–85

1

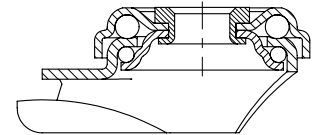

Swivel castors	Fixed castors	Swivel castors with “stop-fix” brake	Wheel Ø [mm]	Wheel width [mm]	Load capacity [kg]	Bearing type	Total height [mm]	Plate Ø [mm]	Bolt hole Ø [mm]	Offset swivel castor [mm]
LRA-PATH 50G	BRA-PATH 50G	LRA-PATH 50G-FI *	50	19	75	plain bore	69	43	11	23
LRA-PATH 50KF	BRA-PATH 50KF	LRA-PATH 50KF-FI *	50	19	75	ball bearing (C)	69	43	11	23
LRA-PATH 75G	BRA-PATH 75G	LRA-PATH 75G-FI *	75	25	75	plain bore	98	43	11	29
LRA-PATH 75KF	BRA-PATH 75KF	LRA-PATH 75KF-FI *	75	25	75	ball bearing (C)	98	43	11	29
LKRA-PATH 80G	BKRA-PATH 80G	LKRA-PATH 80G-FI	80	32	120	plain bore	108	57	13	40
LKRA-PATH 80G-11		LKRA-PATH 80G-11-FI	80	32	120	plain bore	108	57	11	40
LKRA-PATH 80KF	BKRA-PATH 80KF	LKRA-PATH 80KF-FI	80	32	120	ball bearing (C)	108	57	13	40
LKRA-PATH 80KF-11		LKRA-PATH 80KF-11-FI	80	32	120	ball bearing (C)	108	57	11	40
LKRA-PATH 101G	BKRA-PATH 101G	LKRA-PATH 101G-FI	100	32	120	plain bore	133	57	13	40
LKRA-PATH 101G-11		LKRA-PATH 101G-11-FI	100	32	120	plain bore	133	57	11	40
LKRA-PATH 101KF	BKRA-PATH 101KF	LKRA-PATH 101KF-FI	100	32	120	ball bearing (C)	133	57	13	40
LKRA-PATH 101KF-11		LKRA-PATH 101KF-11-FI	100	32	120	ball bearing (C)	133	57	11	40
LKRA-PATH 126G	BKRA-PATH 126G	LKRA-PATH 126G-FI	125	32	120	plain bore	158	57	13	40
LKRA-PATH 126G-11		LKRA-PATH 126G-11-FI	125	32	120	plain bore	158	57	11	40
LKRA-PATH 126KF	BKRA-PATH 126KF	LKRA-PATH 126KF-FI	125	32	120	ball bearing (C)	158	57	13	40
LKRA-PATH 126KF-11		LKRA-PATH 126KF-11-FI	125	32	120	ball bearing (C)	158	57	11	40

* Synthetic brake lever, see image below

For stainless steel versions, see page 394

Versions / options**



	plain bore version	with synthetic brake lever	electrically conductive version, non-marking grey	with threaded pin M10 x 30 M12 x 30	with plug-in pin Ø 11 x 30.5	with synthetic expander fitting	with metal expander fitting
Technical description page			50	104	105	105	105
Product code suffix			-ELS	-GS10 / -GS12	-ES	see page 148	see page 148
Available for		series LRA...-FI as standard	all ball bearing versions***	-GS10: series LRA -GS12: series LKRA	series LRA swivel castors****	swivel castors with bolt hole Ø 11 mm (except ELS)	swivel castors with bolt hole Ø 11 mm

** Other versions / options: 1. bracket in special colours (electrostatic powder coating), available upon request 2. buffers AG / ARG series see page 148 (page 116 for technical information)

*** Wheel load capacity of electrically conductive version reduced by 35%

**** Synthetic castor socket for round tubes see page 148

LPA-PATH, BPA-PATH, LKPA-PATH, BKPA-PATH series

Light duty castors with top plate,
wheel with thermoplastic
polyurethane tread

75–120 kg

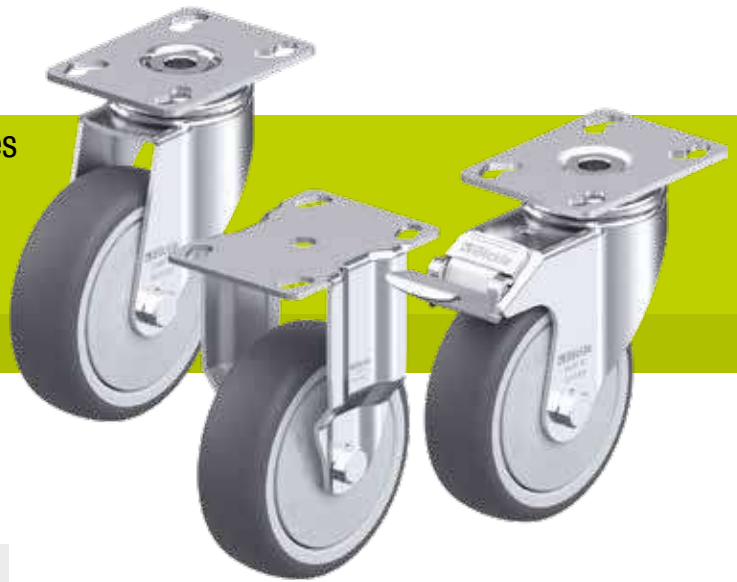

Bracket: LPA/BPA, LKPA/BKPA series

- pressed steel, zinc-plated, blue-passivated, Cr6-free

Swivel bracket:

- double ball bearing in the swivel head
- strong central kingpin
- minimum swivel head play and smooth rolling characteristic and increased service life due to the special dynamic Blickle riveting process
- synthetic "stop-fix" brake lever for series LPA, steel brake lever for series LKPA

Wheel: PATH series

- tread: high-quality thermoplastic polyurethane (TPU), hardness 94 Shore A, colour dark grey, non-marking, non-staining
- wheel centre: high-quality nylon 6, impact resistant, colour silver grey

Additional details:

- bracket series: page 86
- brakes: page 112–113
- wheel series: page 136
- bearing types: page 84–85

1

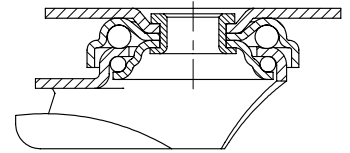

Swivel castors	Fixed castors	Swivel castors with "stop-fix" brake	Wheel Ø [mm]	Wheel width [mm]	Load capacity [kg]	Bearing type	Total height [mm]	Plate size [mm]	Bolt hole spacing [mm]	Bolt hole Ø [mm]	Offset swivel castor [mm]
LPA-PATH 50G	BPA-PATH 50G	LPA-PATH 50G-FI *	50	19	75	plain bore	71	60 x 60	38 x 38 / 48 x 48	6.2	23
LPA-PATH 50KF	BPA-PATH 50KF	LPA-PATH 50KF-FI *	50	19	75	ball bearing (C)	71	60 x 60	38 x 38 / 48 x 48	6.2	23
LPA-PATH 75G	BPA-PATH 75G	LPA-PATH 75G-FI *	75	25	75	plain bore	100	60 x 60	38 x 38 / 48 x 48	6.2	29
LPA-PATH 75KF	BPA-PATH 75KF	LPA-PATH 75KF-FI *	75	25	75	ball bearing (C)	100	60 x 60	38 x 38 / 48 x 48	6.2	29
LKPA-PATH 80G	BKPA-PATH 80G	LKPA-PATH 80G-FI	80	32	120	plain bore	111	90 x 66	75 x 45 / 61 x 51	8.5	40
LKPA-PATH 80KF	BKPA-PATH 80KF	LKPA-PATH 80KF-FI	80	32	120	ball bearing (C)	111	90 x 66	75 x 45 / 61 x 51	8.5	40
LKPA-PATH 101G	BKPA-PATH 101G	LKPA-PATH 101G-FI	100	32	120	plain bore	136	90 x 66	75 x 45 / 61 x 51	8.5	40
LKPA-PATH 101KF	BKPA-PATH 101KF	LKPA-PATH 101KF-FI	100	32	120	ball bearing (C)	136	90 x 66	75 x 45 / 61 x 51	8.5	40
LKPA-PATH 126G	BKPA-PATH 126G	LKPA-PATH 126G-FI	125	32	120	plain bore	161	90 x 66	75 x 45 / 61 x 51	8.5	40
LKPA-PATH 126KF	BKPA-PATH 126KF	LKPA-PATH 126KF-FI	125	32	120	ball bearing (C)	161	90 x 66	75 x 45 / 61 x 51	8.5	40

* Synthetic brake lever, see image below

For stainless steel versions, see page 395

Versions / options



	plain bore version	with synthetic brake lever	electrically conductive version, non-marking grey
Technical description page			50
Product code suffix			-ELS
Available for		series LPA...-FI as standard	all ball bearing versions**

** Wheel load capacity of electrically conductive version reduced by 35%

LMDA-PATH series

Twin wheel light duty castors with bolt hole, wheel with thermoplastic polyurethane tread



1

80–100 kg

Bracket: LMDA series

- pressed steel, zinc-plated, blue-passivated, Cr6-free
- double ball bearing in the swivel head
- pressed swivel head

Wheel: PATH series

- tread: high-quality thermoplastic polyurethane (TPU), hardness 94 Shore A, colour dark grey, non-marking, non-staining
- wheel centre: high-quality nylon 6, impact resistant, colour silver grey

Additional details:

- bracket series: page 86
- brakes: page 112–113
- wheel series: page 136
- bearing types: page 84–85

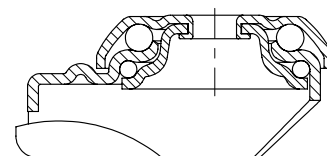

Swivel castors	Swivel castors with "stop-fix" brake	Wheel Ø [mm]	Wheel width [mm]	Load capacity [kg]	Bearing type	Total height [mm]	Plate Ø [mm]	Bolt hole Ø [mm]	Offset swivel castor [mm]
LMDA-PATH 50G	LMDA-PATH 50G-FI	50	2 x 19	80	plain bore	71	41	10.2	31
LMDA-PATH 50KF	LMDA-PATH 50KF-FI	50	2 x 19	80	ball bearing (C)	71	41	10.2	31
LMDA-PATH 75G	LMDA-PATH 75G-FI	75	2 x 25	100	plain bore	98	55	10.2	34
LMDA-PATH 75KF	LMDA-PATH 75KF-FI	75	2 x 25	100	ball bearing (C)	98	55	10.2	34

Versions / options



	plain bore version	electrically conductive version, non-marking grey
Technical description page		50
Product code suffix		-ELS
Available for		all ball bearing versions*

* Wheel load capacity of electrically conductive version reduced by 35%

LDA-PATH series

Twin wheel light duty castors with top plate, wheels with thermoplastic polyurethane tread



80–100 kg

Bracket: LDA series

- pressed steel, zinc-plated, blue-passivated, Cr6-free
- double ball bearing in the swivel head
- pressed swivel head

Wheel: PATH series

- tread: high-quality thermoplastic polyurethane (TPU), hardness 94 Shore A, colour dark grey, non-marking, non-staining
- wheel centre: high-quality nylon 6, impact resistant, colour silver grey

Additional details:

- bracket series: page 86
- brakes: page 112–113
- wheel series: page 136
- bearing types: page 84–85

1

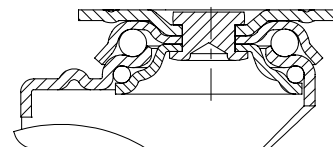

Swivel castors	Swivel castors with "stop-fix" brake	Wheel Ø [mm]	Wheel width [mm]	Load capacity [kg]	Bearing type	Total height [mm]	Plate size [mm]	Bolt hole spacing [mm]	Bolt hole Ø [mm]	Offset swivel castor [mm]
LDA-PATH 50G	LDA-PATH 50G-FI	50	2 x 19	80	plain bore	71	60 x 60	38 x 38 / 48 x 48	6.2	31
LDA-PATH 50KF	LDA-PATH 50KF-FI	50	2 x 19	80	ball bearing (C)	71	60 x 60	38 x 38 / 48 x 48	6.2	31
LDA-PATH 75G	LDA-PATH 75G-FI	75	2 x 25	100	plain bore	101	60 x 60	40 x 40 / 46 x 46	6.2	34
LDA-PATH 75KF	LDA-PATH 75KF-FI	75	2 x 25	100	ball bearing (C)	101	60 x 60	40 x 40 / 46 x 46	6.2	34

Versions / options



	plain bore version	electrically conductive version, non-marking grey
Technical description page		50
Product code suffix		-ELS
Available for		all ball bearing versions*

* Wheel load capacity of electrically conductive version reduced by 35%

LRA-VSTH, LKRA-VSTH series

Light duty castors with bolt hole,
wheel with Blickle Extrathane®
polyurethane tread



100–150 kg

Bracket: LRA/LKRA series

- pressed steel, zinc-plated, blue-passivated, Cr6-free
- double ball bearing in the swivel head
- strong central kingpin
- minimum swivel head play and smooth rolling characteristic and increased service life due to the special dynamic Blickle riveting process

Wheel: VSTH series

- tread: high-quality polyurethane elastomer Blickle Extrathane®, hardness 92 Shore A, colour light brown, non-marking, non-staining
- wheel centre: steel

Additional details:

- bracket series: page 86
- brakes: page 112–113
- wheel series: page 66
- bearing types: page 84–85



1

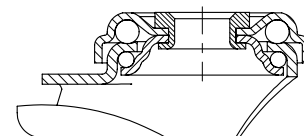

Swivel castors	Swivel castors with "Radstop" brake	Wheel Ø [mm]	Wheel width [mm]	Load capacity [kg]	Bearing type	Total height [mm]	Plate Ø [mm]	Bolt hole Ø [mm]	Offset swivel castor [mm]
LRA-VSTH 35K	LRA-VSTH 35K-RA	35	27	100	ball bearing	50	43	11	15
LKRA-VSTH 50K	LKRA-VSTH 50K-RA	50	33	150	ball bearing	70	57	13	29

For additional castors with a high load capacity and low total height, see the "Compact castors" section

Versions / options



	with threaded pin M10 x 30	with threaded pin M12 x 30	buffers
Technical description page	104	104	116
Product code suffix	-GS10	-GS12	AG / ARG series
Available for	LRA-VSTH 35K*	LKRA-VSTH 50K	see page 148

* Load capacity reduced by 20%

LPA-VSTH, LKPA-VSTH series

Light duty castors with top plate,
wheel with Blickle Extrathane®
polyurethane tread



100–150 kg

Bracket: LPA/LKPA series

- pressed steel, zinc-plated, blue-passivated, Cr6-free
- double ball bearing in the swivel head
- strong central kingpin
- minimum swivel head play and smooth rolling characteristic and increased service life due to the special dynamic Blickle riveting process

Wheel: VSTH series

- tread: high-quality polyurethane elastomer Blickle Extrathane®, hardness 92 Shore A, colour light brown, non-marking, non-staining
- wheel centre: steel

Additional details:

- bracket series: page 86
- brakes: page 112–113
- wheel series: page 66
- bearing types: page 84–85



1

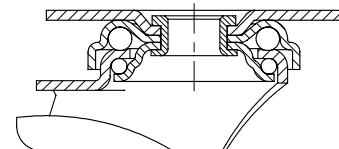
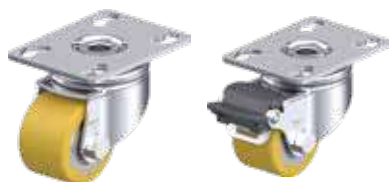

Swivel castors	Swivel castors with "Radstop" brake	Wheel Ø [mm]	Wheel width [mm]	Load capacity [kg]	Bearing type	Total height [mm]	Plate size [mm]	Bolt hole spacing [mm]	Bolt hole Ø [mm]	Offset swivel castor [mm]
LPA-VSTH 35K	LPA-VSTH 35K-RA	35	27	100	ball bearing	52	60 x 60	38 x 38 / 48 x 48	6.2	15
LKPA-VSTH 50K	LKPA-VSTH 50K-RA	50	33	150	ball bearing	73	90 x 66	75 x 45 / 61 x 51	8.5	29

For additional castors with a high load capacity and low total height, see the "Compact castors" section

POA series

Nylon wheels

75–280 kg

Tread and tyre hardness

70 Shore D

Smooth operation / floor preservation

satisfactory

Rolling resistance

excellent

Wear resistance

good



1

Wheel:

- high-quality nylon 6, impact resistant, hardness 70 Shore D
- excellent rolling and swivel resistance
- easy operation on smooth surfaces
- high abrasion resistance
- colour black

Other features:

- high chemical resistance to many aggressive substances
- operating temperature: -20 °C to +80 °C, reduced load capacity over +35 °C

Additional details:

- wheel series: page 61
- tread: page 57
- bearing types: page 84–85
- chemical resistance: page 51

Wheels	Wheel Ø	Wheel width	Load capacity	Bearing type	Axle bore Ø	Hub length
	(D) [mm]	(T2) [mm]	[kg]		(d) [mm]	(T1) [mm]
POA 35/8G	35	25	75	plain bore	8	29.5
POA 50/8G	50	18	75	plain bore	8	22
POA 52/12G	50	29	120	plain bore	12	31
POA 58/10G	58	29	100	plain bore	10	31
POA 65/10G	65	30	100	plain bore	10	33
POA 65/12G	65	30	100	plain bore	12	33
POA 75/8G	75	23	100	plain bore	8	29.5
POA 80/12G	80	32	220	plain bore	12	35
POA 102/8G	100	22	100	plain bore	8	29.5
POA 100/8K	100	30	240	ball bearing (C)	8	36
POA 100/12G	100	32	240	plain bore	12	35
POA 125/8K	125	30	260	ball bearing (C)	8	36
POA 125/12G	125	32	260	plain bore	12	35
POA 150/12G	150	32	280	plain bore	12	35

For additional nylon wheels, see page 343, 344

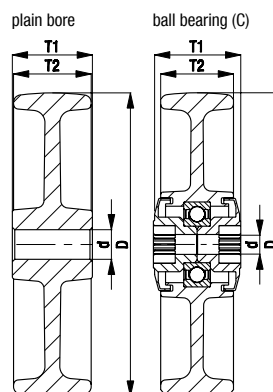

LRA-POA, BRA-POA, LKRA-POA, BKRA-POA series

Light duty castors with bolt hole, with nylon wheel

70–120 kg

Bracket: LRA/BRA, LKRA/BKRA series
 • pressed steel, zinc-plated, blue-passivated, Cr6-free

Swivel bracket:

- double ball bearing in the swivel head
- strong central kingpin
- minimum swivel head play and smooth rolling characteristic and increased service life due to the special dynamic Blickle riveting process
- synthetic “stop-fix” brake lever for series LRA, steel brake lever for series LKRA

Wheel: POA series
 • high-quality nylon 6, impact resistant, hardness 70 Shore D, colour black

Additional details:

- bracket series: page 86
- brakes: page 112–113
- wheel series: page 143
- bearing types: page 84–85

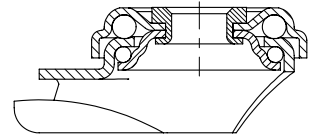

Swivel castors	Fixed castors	Swivel castors with “stop-fix” brake	Wheel Ø [mm]	Wheel width [mm]	Load capacity [kg]	Bearing type	Total height [mm]	Plate Ø [mm]	Bolt hole Ø [mm]	Offset swivel castor [mm]
LRA-POA 35G		LRA-POA 35G-RA *	35	25	75	plain bore	50	43	11	15
LRA-POA 50G	BRA-POA 50G	LRA-POA 50G-FI **	50	18	75	plain bore	69	43	11	23
LKRA-POA 52G		LKRA-POA 52G-RA *	50	29	120	plain bore	70	57	13	29
LRA-POA 75G	BRA-POA 75G	LRA-POA 75G-FI **	75	23	75	plain bore	98	43	11	29
LKRA-POA 80G	BKRA-POA 80G	LKRA-POA 80G-FI	80	32	120	plain bore	108	57	13	40
LKRA-POA 80G-11		LKRA-POA 80G-11-FI	80	32	120	plain bore	108	57	11	40
LRA-POA 102G		LRA-POA 102G-FI **	100	22	70	plain bore	121	43	11	33
LKRA-POA 100K	BKRA-POA 100K	LKRA-POA 100K-FI	100	30	120	ball bearing (C)	133	57	13	40
LKRA-POA 100K-11		LKRA-POA 100K-11-FI	100	30	120	ball bearing (C)	133	57	11	40
LKRA-POA 100G	BKRA-POA 100G	LKRA-POA 100G-FI	100	32	120	plain bore	133	57	13	40
LKRA-POA 100G-11		LKRA-POA 100G-11-FI	100	32	120	plain bore	133	57	11	40
LKRA-POA 125K	BKRA-POA 125K	LKRA-POA 125K-FI	125	30	120	ball bearing (C)	158	57	13	40
LKRA-POA 125K-11		LKRA-POA 125K-11-FI	125	30	120	ball bearing (C)	158	57	11	40
LKRA-POA 125G	BKRA-POA 125G	LKRA-POA 125G-FI	125	32	120	plain bore	158	57	13	40
LKRA-POA 125G-11		LKRA-POA 125G-11-FI	125	32	120	plain bore	158	57	11	40
LKRA-POA 150G	BKRA-POA 150G	LKRA-POA 150G-FI	150	32	110	plain bore	182	57	13	40
LKRA-POA 150G-11		LKRA-POA 150G-11-FI	150	32	110	plain bore	182	57	11	40

* “Radstop” brake version

** Synthetic brake lever, see image below

For stainless steel versions, see page 396

Versions / options



	with synthetic brake lever	“Radstop” wheel brake	with threaded pin M10 x 30 M12 x 30	with plug-in pin Ø 11 x 30.5	with synthetic expander fitting	with metal expander fitting	buffers
Technical description page			104	105	105	105	116
Product code suffix			-GS10 / -GS12	-ES	see page 148	see page 148	AG / ARG series
Available for	series LRA...-FI as standard	series LRA Ø 35 mm series LKRA Ø 50 mm	-GS10: series LRA -GS12: series LKRA	series LRA swivel castors***	swivel castors bolt hole Ø 11 mm (with exception of Ø 35 mm)	swivel castors bolt hole Ø 11 mm (with exception of Ø 35 mm)	see page 148

*** Synthetic castor socket for round tubes see page 148

LPA-POA, BPA-POA, LKPA-POA, BKPA-POA series

Light duty castors with top plate, with nylon wheel

70–120 kg



Bracket: LPA/BPA, LKPA/BKPA series

- pressed steel, zinc-plated, blue-passivated, Cr6-free

Swivel bracket:

- double ball bearing in the swivel head
- strong central kingpin
- minimum swivel head play and smooth rolling characteristic and increased service life due to the special dynamic Blickle riveting process
- synthetic “stop-fix” brake lever for series LPA, steel brake lever for series LKPA

Wheel: POA series

- high-quality nylon 6, impact resistant, hardness 70 Shore D, colour black

Additional details:

- bracket series: page 86
- brakes: page 112–113
- wheel series: page 143
- bearing types: page 84–85

1

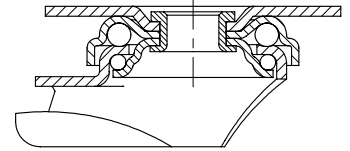

Swivel castors	Fixed castors	Swivel castors with “stop-fix” brake	Wheel Ø [mm]	Wheel width [mm]	Load capacity [kg]	Bearing type	Total height [mm]	Plate size [mm]	Bolt hole spacing [mm]	Bolt hole Ø [mm]	Offset swivel castor [mm]
LPA-POA 35G		LPA-POA 35G-RA *	35	25	75	plain bore	52	60 x 60	38 x 38 / 48 x 48	6.2	15
LPA-POA 50G	BPA-POA 50G	LPA-POA 50G-FI **	50	18	75	plain bore	71	60 x 60	38 x 38 / 48 x 48	6.2	23
LKPA-POA 52G		LKPA-POA 52G-RA *	50	29	120	plain bore	73	90 x 66	75 x 45 / 61 x 51	8.5	29
LPA-POA 75G	BPA-POA 75G	LPA-POA 75G-FI **	75	23	75	plain bore	100	60 x 60	38 x 38 / 48 x 48	6.2	29
LKPA-POA 80G	BKPA-POA 80G	LKPA-POA 80G-FI	80	32	120	plain bore	111	90 x 66	75 x 45 / 61 x 51	8.5	40
LPA-POA 102G		LPA-POA 102G-FI **	100	22	70	plain bore	123	60 x 60	38 x 38 / 48 x 48	6.2	33
LKPA-POA 100K	BKPA-POA 100K	LKPA-POA 100K-FI	100	30	120	ball bearing (C)	136	90 x 66	75 x 45 / 61 x 51	8.5	40
LKPA-POA 100G	BKPA-POA 100G	LKPA-POA 100G-FI	100	32	120	plain bore	136	90 x 66	75 x 45 / 61 x 51	8.5	40
LKPA-POA 125K	BKPA-POA 125K	LKPA-POA 125K-FI	125	30	120	ball bearing (C)	161	90 x 66	75 x 45 / 61 x 51	8.5	40
LKPA-POA 125G	BKPA-POA 125G	LKPA-POA 125G-FI	125	32	120	plain bore	161	90 x 66	75 x 45 / 61 x 51	8.5	40
LKPA-POA 150G	BKPA-POA 150G	LKPA-POA 150G-FI	150	32	110	plain bore	185	90 x 66	75 x 45 / 61 x 51	8.5	40

* “Radstop” brake version

** Synthetic brake lever, see image below

For stainless steel versions, see page 397

Versions / options



with synthetic brake lever “Radstop” wheel brake

Technical description page

Product code suffix

Available for series LPA...-FI as standard series LPA Ø 35 mm series LKPA Ø 50 mm

LMDA-POA series

Twin wheel light duty castors with bolt hole, with nylon wheels

80–100 kg

Bracket: LMDA series

- pressed steel, zinc-plated, blue-passivated, Cr6-free
- double ball bearing in the swivel head
- pressed swivel head

Wheel: POA series

- high-quality nylon 6, impact resistant, hardness 70 Shore D, colour black

Additional details:

- bracket series: page 86
- brakes: page 112–113
- wheel series: page 143
- bearing types: page 84–85



1

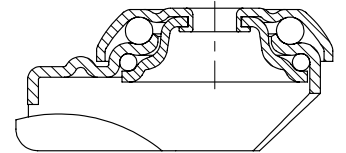

Swivel castors	Swivel castors with "stop-fix" brake	Wheel Ø [mm]	Wheel width [mm]	Load capacity [kg]	Bearing type	Total height [mm]	Plate Ø [mm]	Bolt hole Ø [mm]	Offset swivel castor [mm]
LMDA-POA 50G	LMDA-POA 50G-FI	50	2 x 18	80	plain bore	71	41	10.2	31
LMDA-POA 75G	LMDA-POA 75G-FI	75	2 x 23	100	plain bore	98	55	10.2	34

LDA-POA series

Twin wheel light duty castors with top plate, with nylon wheels

80–100 kg

Bracket: LDA series

- pressed steel, zinc-plated, blue-passivated, Cr6-free
- double ball bearing in the swivel head
- pressed swivel head

Wheel: POA series

- high-quality nylon 6, impact resistant, hardness 70 Shore D, colour black

Additional details:

- bracket series: page 86
- brakes: page 112–113
- wheel series: page 143
- bearing types: page 84–85



1

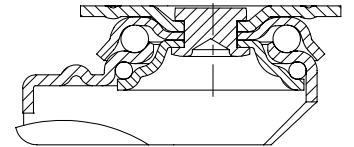

Swivel castors	Swivel castors with "stop-fix" brake	Wheel Ø [mm]	Wheel width [mm]	Load capacity [kg]	Bearing type	Total height [mm]	Plate size [mm]	Bolt hole spacing [mm]	Bolt hole Ø [mm]	Offset swivel castor [mm]
LDA-POA 50G	LDA-POA 50G-FI	50	2 x 18	80	plain bore	71	60 x 60	38 x 38 / 48 x 48	6.2	31
LDA-POA 75G	LDA-POA 75G-FI	75	2 x 23	100	plain bore	101	60 x 60	40 x 40 / 46 x 46	6.2	34